

COTTON SWEEPS (JOYCE PATTERN)

- A. HOLE PATTERNS:** two 7/16" plow bolt holes on 2-1/4" centers and 1 middle hole for 5/8" carriage bolt.
B. STEM:
 1. TYPE: Wrap around.
 2. ANGLE: 55°
C. CROWN: Medium
D. WING TYPE: Extra Wide

| SIZE | PLAIN PART NUMBER | WT |
|----------|-------------------|------|
| 1/4"X6" | TP112-06 | 2.71 |
| 1/4"X8" | TP112-08 | 3.12 |
| 1/4"X10" | TP112-10 | 3.34 |
| 1/4"X12" | TP112-12 | 4.10 |
| 1/4"X14" | TP112-14 | 5.04 |
| 1/4"X16" | TP112-16 | 5.69 |
| 1/4"X18" | TP112-18 | 6.37 |
| 1/4"X20" | TP112-20 | 7.73 |
| 1/4"X22" | TP112-22 | 8.18 |
| 1/4"X24" | TP112-24 | 8.58 |

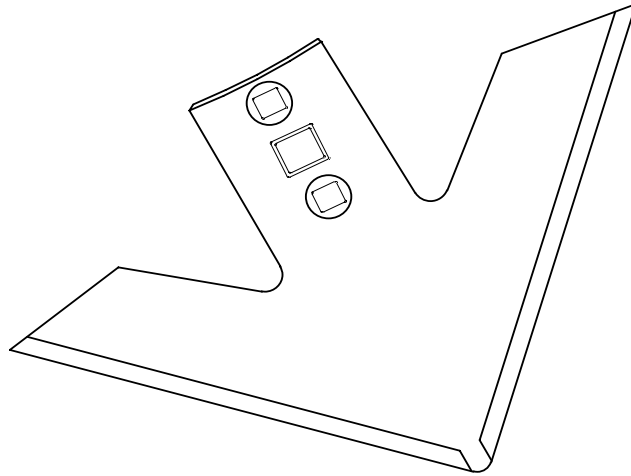

*Other size sweeps may be special ordered including 28", 32", and 36" welded sweeps

12 SERIES FLANGE STEM CULTIVATOR SWEEPS:

- A. HOLE PATTERNS:** two 7/16" plow bolt holes on 2" centers and center hole for 5/8" carriage bolt.
B. STEM:
 1. TYPE: Wrap around.
 2. ANGLE: 55°
C. CROWN: Medium
D. WING TYPE: Medium Wide

| SIZE | PLAIN PART NUMBER | WT |
|----------|-------------------|------|
| 1/4"X4" | TP12-04 | 1.47 |
| 1/4"X6" | TP12-06 | 1.92 |
| 1/4"X8" | TP12-08 | 2.52 |
| 1/4"X10" | TP12-10 | 3.17 |
| 1/4"X12" | TP12-12 | 3.37 |
| 1/4"X14" | TP12-14 | 4.17 |
| 1/4"X16" | TP12-16 | 4.62 |
| 1/4"X18" | TP12-18 | 4.82 |
| 1/4"X20" | TP12-20 | 5.40 |
| 1/4"X22" | TP12-22 | 5.80 |
| 1/4"X24" | TP12-24 | 6.00 |
| 1/4"x26" | TP12-26 | 7.9 |
| 1/4"X28" | TP12-28 | 8.2 |
| 1/4"X30" | TP12-30 | 8.5 |

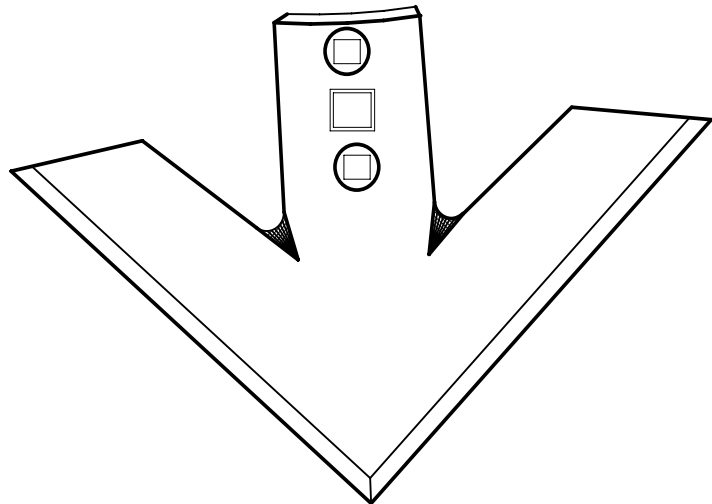

SWEEPS MAY BE ORDERED WITH THE FOLLOWING PREFIXES: (TP) PLAIN SWEEP, (TH) HARDFACED SWEEP, (TC) CHROME INSERTED-SWEEP.

CHISEL PLOW SWEEPS: Chisel Plow Sweeps were designed for use in the dry land grain market. They have thick, heavy wings, with medium high crowns and wrap around necks.

A. HOLE PATTERN: See chart below.

B. STEM:

1. **TYPE:** NA
2. **ANGLE:** 43° and 50°

C. CROWN: Medium

D. WING TYPE: Extra Wide

| SIZE | O. E. M. EQUIP. | PLAIN PART # | BOLT SIZE | BOLT CENTER | WT. |
|-----------|-----------------|--------------|-----------|-------------|------|
| 1/4"X12" | MORRIS | TPF43-12K | 1/2" | 2-1/4" | 5.44 |
| 1/4"X14" | MORRIS | TPF43-14K | 1/2" | 2-1/4" | 6.68 |
| 1/4"X16" | MORRIS | TPF43-16K | 1/2" | 2-1/4" | 7.04 |
| 1/4"X18" | MORRIS | TPF43-18K | 1/2" | 2-1/4" | 8.25 |
| 1/4"X12" | CASE/I. H. | TPF43-12I | 1/2" | 2-1/2" | 5.44 |
| 1/4"X14" | CASE/I. H. | TPF43-14I | 1/2" | 2-1/2" | 6.68 |
| 1/4"X16" | CASE/I. H. | TPF43-16I | 1/2" | 2-1/2" | 7.04 |
| 1/4"X18" | CASE/I. H. | TPF43-18I | 1/2" | 2-1/2" | 8.25 |
| 1/4"X12" | J.D. | TPF50-12K | 1/2" | 2-1/4" | 5.44 |
| 1/4"X14" | J.D. | TPF50-14K | 1/2" | 2-1/4" | 6.68 |
| 1/4"X16" | J.D. | TPF50-16K | 1/2" | 2-1/4" | 7.04 |
| 1/4"X18" | J.D. | TPF50-18K | 1/2" | 2-1/4" | 8.25 |
| 5/16"X12" | J.D. | TPF50-125K | 1/2" | 2-1/4" | 6.63 |
| 5/16"X14" | J.D. | TPF50-145K | 1/2" | 2-1/4" | 7.64 |
| 5/16"X16" | J.D. | TPF50-165K | 1/2" | 2-1/4" | 8.68 |
| 5/16"X18" | J.D. | TPF50-185K | 1/2" | 2-1/4" | 9.30 |

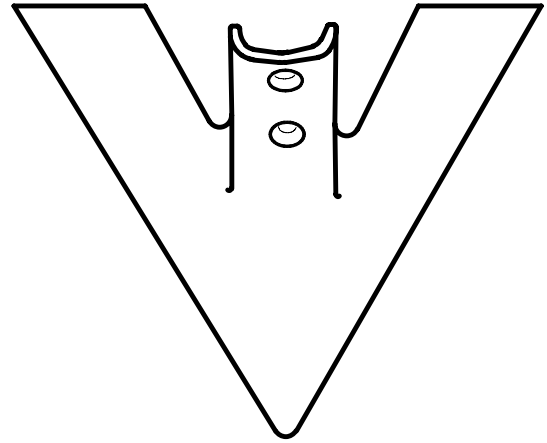

PENETRATOR SWEEPS: Deep tillage.

A. HOLE PATTERN: See chart below.

B. STEM:

1. **TYPE:** NA
2. **ANGLE:** 43° and 50°

C. CROWN: Medium

D. WING TYPE: Extra Wide

| SIZE | PLAIN PART # | BOLT SIZE | BOLT CENTER | WT. |
|-----------|--------------|-----------|-------------|------|
| 1/4"X12" | TPP43-12K | 1/2" | 2-1/4" | 5.44 |
| 1/4"X16" | TPP43-16K | 1/2" | 2-1/4" | 7.04 |
| 1/4"X 6" | TPP50-6K | 1/2" | 2-1/4" | 4.59 |
| 1/4"X 8" | TPP50-8K | 1/2" | 2-1/4" | 4.60 |
| 1/4"X 10" | TPP50-10K | 1/2" | 2-1/4" | 5.18 |
| 1/4"X12" | TPP50-12K | 1/2" | 2-1/4" | 5.44 |
| 1/4"X14" | TPP50-14K | 1/2" | 2-1/4" | 6.68 |
| 1/4"X16" | TPP50-16K | 1/2" | 2-1/4" | 7.04 |
| 1/4"X18" | TPP50-18K | 1/2" | 2-1/4" | 8.25 |
| 5/16"X10" | TPP50-105K | 1/2" | 2-1/4" | 6.63 |
| 5/16"X12" | TPP50-125K | 1/2" | 2-1/4" | 6.63 |
| 5/16"X14" | TPP50-145K | 1/2" | 2-1/4" | 7.64 |
| 5/16"X16" | TPP50-165K | 1/2" | 2-1/4" | 8.68 |
| 5/16"X18" | TPP50-185K | 1/2" | 2-1/4" | 9.30 |

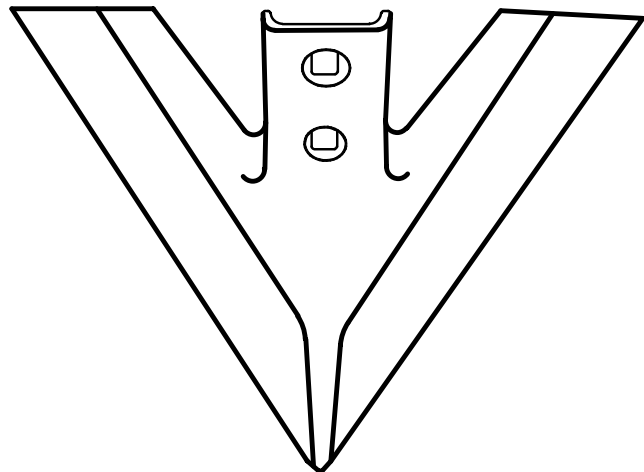

SWEEPS MAY BE ORDERED WITH THE FOLLOWING PREFIXES: (TP) PLAIN SWEEP. (TH) HARDFACED SWEEP. (TC) CHROME INSERTED-SWEEP.

UNIVERSAL ECONOMY SWEEPS- The Universal sweep is designed for use on all row crop cultivators. They have thick, heavy wings with wide, medium crowns and flat necks.

A. HOLE PATTERNS: 2-7/16" plow bolt holes on 2 1/4" centers and 1" middle hole for a 5/8" carriage bolt.

B. STEM:
 1. **TYPE:** Flat.
 2. **ANGLE:** 55°

C. CROWN: Medium

D. WING TYPE: Medium Wide

| SIZE | PLAIN PART # | WT. |
|----------|--------------|------|
| 1/4"X4" | TPE150-04 | 1.10 |
| 1/4"X6" | TPE150-06 | 1.50 |
| 1/4"X8" | TPE150-08 | 2.25 |
| 1/4"X10" | TPE150-10 | 2.70 |
| 1/4"X12" | TPE150-12 | 3.50 |
| 1/4"X14" | TPE150-14 | 4.50 |
| 1/4"X16" | TPE150-16 | 5.20 |
| 1/4"X18" | TPE150-18 | 6.90 |
| 1/4"X20" | TPE150-20 | 8.20 |
| 1/4"X22" | TPE150-22 | 9.40 |
| 1/4"X24" | TPE150-24 | 9.90 |

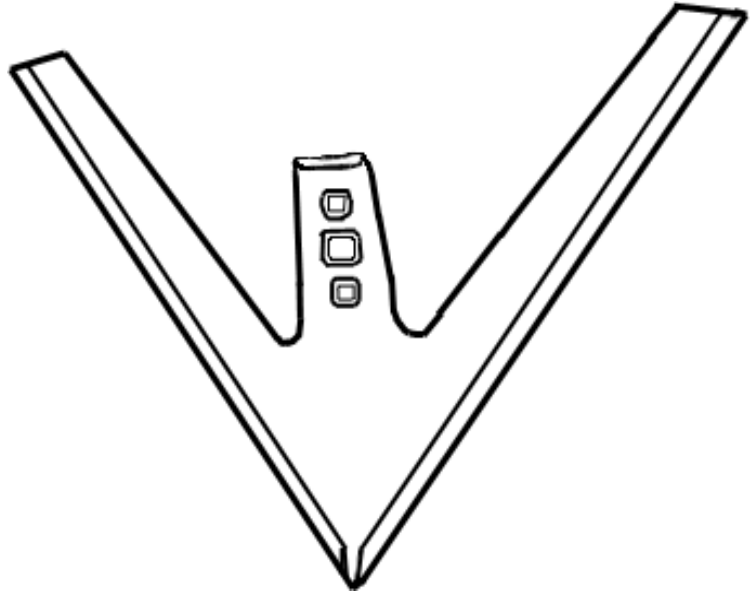

SWEEPS MAY BE ORDERED WITH THE FOLLOWING PREFIXES: (TP) PLAIN SWEEP, (TH) HARDFACED SWEEP, (TC) CHROME INSERTED-SWEEP.

PEANUT SWEEP:

A. HOLE PATTERNS: 1-1/4" – 2-1/4" centers for 7/16" plow bolt.

B. STEM:
 1. **TYPE:** Flanged.
 2. **ANGLE:** 56°

C. CROWN: Low

D. WING TYPE: Extra Wide

| SIZE | PLAIN PART # | WT. |
|-----------|--------------|------|
| 8"X3/16" | TP131-08 | 1.30 |
| 10"X3/16" | TP131-10 | 1.83 |
| 12"X3/16" | TP131-12 | 2.16 |
| 14"X3/16" | TP132-14 | 3.00 |
| 16"X3/16" | TP132-16 | 3.58 |
| 18"X3/16" | TP132-18 | N/A |

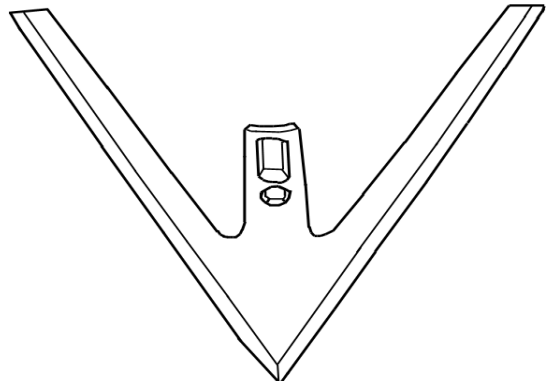

SWEEPS MAY BE ORDERED WITH THE FOLLOWING PREFIXES: (TP) PLAIN SWEEP, (TH) HARDFACED SWEEP, (TC) CHROME INSERTED-SWEEP.

FIELD CULTIVATOR SWEEPS- Field Cultivator sweeps are designed for high speed, dry land grain farming. They have a wrap around neck for extra strength.

A. HOLE PATTERNS: Two 7/16" plow bolt holes on 1-3/4" centers.

B. STEM:

1. **TYPE:** Wrap around.
2. **ANGLE:** 47 degrees

C. CROWN: Low

D. WING TYPE: Long wearing parallel wing to 9".

| SIZE | O. E. M. EQUIP. | PLAIN PART # | WT. |
|----------|-----------------|--------------|------|
| 1/4"X6" | GLENCOE, | TP202-06 | 1.59 |
| 1/4"X4" | CASE FC, | TP202-044 | 1.88 |
| 1/4"X6" | JEOFFROY, | NA | 2.20 |
| 1/4"X7" | MINN-MOL., | TP202-074 | 2.32 |
| 1/4"X8" | FORD, | TP202-084 | 2.33 |
| 1/4"X9" | MASSEY, | TP202-094 | 2.60 |
| 1/4"X10" | OLIVER, BUSH | TP202-104 | 3.10 |
| 1/4"X12" | HOG, TAYLOR, | TP202-124 | 3.43 |

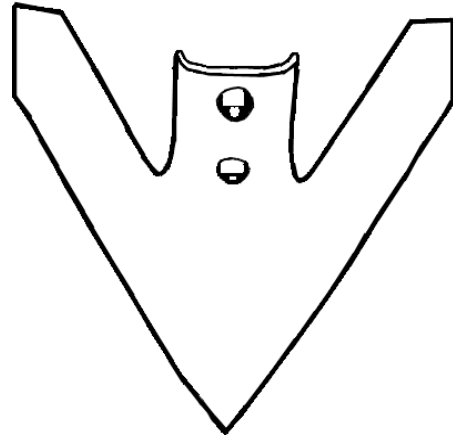

DANISH "B" SWEEPS: - Made especially for the "S" tine shank to be used in all crop applications. Made from high carbon steel then heat treated for the extra long wear.

A. HOLE PATTERN: 1-3/8" plow bolt hole.

C. CROWN: Low

D. WING TYPE: Long Wear

| SIZE | PLAIN PART NUMBER | WT |
|-----------|-------------------|------|
| 6"X3/16" | TPB3206S | .90 |
| 8"X3/16" | TPB3208S | 1.08 |
| 10"X3/16" | TPB3210S | 1.26 |
| 12"X3/16" | TPB3212S | 1.45 |
| 14"X3/16" | TPB3214S | 1.64 |
| 16"X3/16" | TPB3216S | 1.77 |

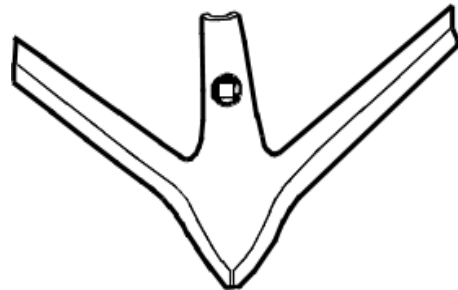

DANISH "S" TINES AND POINT- Made especially for the "S" tine shank to be used in all crop applications. Made from high carbon steel then heat treated for the extra long wear.

A. HOLE PATTERN: 1-3/8" plow bolt hole.

C. CROWN: Low

D. WING TYPE: Long Wear

| SIZE | PLAIN PART # | PART NUMBER IMPORT | |
|---------------|--------------|--------------------|--------|
| | | 3/16" | 1/4" |
| POINT | 1/4" | | |
| 1"X8" | TPVM01 | TPV01 | TPVA01 |
| SWEEPS | | | |
| 2-3/4" | TPVM02 | TPV02 | TPVA02 |
| 4" GOOSE FT. | TPVM04 | TPV04 | TPVA04 |
| 4" WINGED | TPVM44 | TPV44 | TPVA44 |
| 5" | TPVM05 | | |
| 7" | TPVM07 | TPV07 | TPVA07 |
| 10" | TPVM10 | TPV10 | TPVA10 |

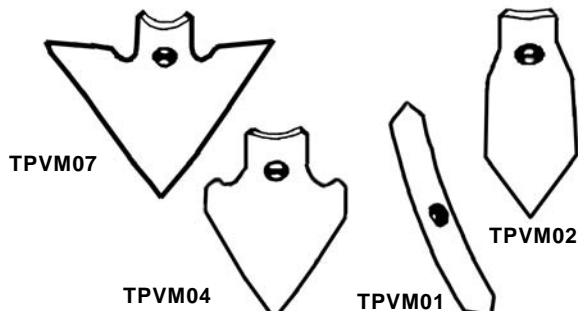

SWEEPS MAY BE ORDERED WITH THE FOLLOWING PREFIXES: (TP) PLAIN SWEEP. (TH) HARDFACED SWEEP. (TC) CHROME INSERTED-SWEEP.

ALABAMA (SOLID) SWEEPS- The Alabama Sweeps were designed for use in the western cotton market. They are made from 1/4" thick plow steel for extra long life.

A. HOLE PATTERNS: Two 7/16" plow bolt holes on 2-1/4" centers and center hole for 5/8" carriage bolt.

B. STEM:

- 1. TYPE: Solid.
- 2. ANGLE: NA

C. CROWN: Low

D. WING TYPE: None Solid.

| SIZE | PLAIN PART NUMBER | WT |
|----------|-------------------|-------|
| 1/4"X8" | TPE47-08 | 1.95 |
| 1/4"X10" | TPE47-10 | 2.35 |
| 1/4"X12" | TPE47-12 | 3.35 |
| 1/4"X14" | TPE47-14 | 4.40 |
| 1/4"X16" | TPE47-16 | 5.95 |
| 1/4"X18" | TPE47-18 | 8.10 |
| 1/4"X20" | TPE47-20 | 9.00 |
| 1/4"X22" | TPE47-22 | 10.25 |
| 1/4"X24" | TPE47-24 | 11.10 |
| 1/4"X28" | TPE47-28 | 13.75 |

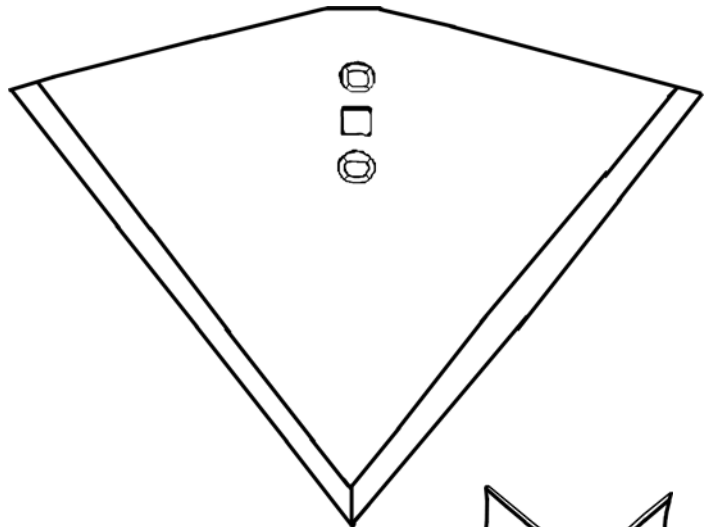

IRRIGATION SHOVELS (MULE SHOES)

| SIZE | PLAIN PART # | BOLT SIZE | WT |
|----------|--------------|-----------|------|
| 3/16"X6" | TPS1026 | 3/8" | 3.25 |
| 3/16"X7" | TPS1027 | 3/8" | 4.90 |
| 3/16"X8" | TPS1028 | 3/8" | 4.90 |
| 3/16"X9" | TPS1029 | 3/8" | 5.10 |

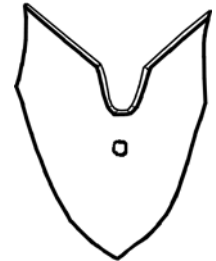

ALABAMA SWEEPS & IRRIGATION STEELS MAY BE ORDERED WITH THE FOLLOWING PREFIXES: (TP) PLAIN, (TH) HARDFACED, (TC) CHROME INSERT.

WYOMING SHOVEL WITH HARDFACING: Shovels are made from 3/16" material and brackets are made from 1/4" material.

| PART NO. | DESCRIPTION | WT. LBS | STANDARD SIZE |
|----------|------------------------------|---------|--------------------|
| WS-4 | 4" STD. DUTY WYOMING SHOVEL | 6.58 | 5/8" X 1-1/2" X 2" |
| WS-6 | 6" STD. DUTY WYOMING SHOVEL | 6.8 | 5/8" X 1-1/2" X 2" |
| WS-8 | 8" STD. DUTY WYOMING SHOVEL | 10.8 | 3/4" X 2" X 2-1/2" |
| WS-10 | 10" STD. DUTY WYOMING SHOVEL | 16.56 | 3/4" X 2" X 2-1/2" |
| WS-12 | 12" STD. DUTY WYOMING SHOVEL | 22.2 | 3/4" X 2" X 2-1/2" |

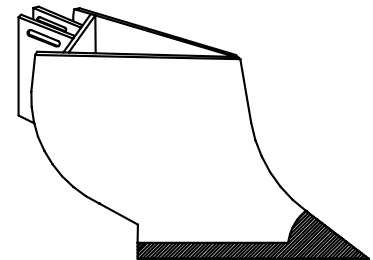

HEAVY DUTY WYOMING SHOVEL WITH HARDFACING: Shovels and brackets are made from 1/4" material.

| PART NO. | DESCRIPTION | WT. LBS | STANDARD SIZE |
|----------|------------------------------|---------|---------------|
| WSHD-06 | 6" HEAVY DUTY WYOMING SHOVEL | 7.5 | ALL SIZES |
| WSHD-08 | 8" HEAVY DUTY WYOMING SHOVEL | 13.08 | ALL SIZES |

WSHD'S ARE FITTED WITH THE C101 CHROME ALLOY POINT

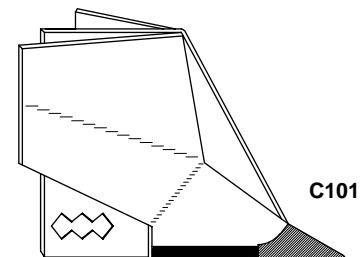

FURROWERS (HIGH WING)- Standard furrowers for all row crop applications.

A. HOLE PATTERNS: Two slotted holes and one square hole between, for 1-1/4" on 2-1/4" centers for a 7/16" plow bolts.

C. CROWN: Medium
D. WING TYPE: High Wing.

| SIZE | PLAIN PART NUMBER | WT |
|-----------|-------------------|-------|
| 3/16"X8" | TPS1029 | 4.25 |
| 3/16"X10" | TPS1030 | 4.35 |
| 3/16"X12" | TPS1031 | 6.05 |
| 3/16"X15" | TPS1032 | 8.60 |
| 3/16"X18" | TPS1033 | 11.50 |

32 SERIES & ADAMS 600 SERIES FURROWER: 2 Holes, on 2-1/4" centers for 7/16" plow bolts and 1 square hole for 5/8" carriage bolt.

| PLAIN PART # | SIZE | WT | ADAMS' PART # | SIZE | WT |
|--------------|----------|-------|---------------|----------|-------|
| TP3235 | 1/4"X8" | 8.25 | TP608 | 1/4"X6" | 5.00 |
| TP3236 | 1/4"X10" | 8.55 | TP610 | 1/4"X8" | 5.00 |
| TP3237 | 1/4"X12" | 10.85 | TP612 | 1/4"X10" | 8.80 |
| TP3238 | 1/4"X15" | 13.25 | TP615 | 1/4"X12" | 10.20 |
| TP3239 | 1/4"X18" | 15.85 | TP618 | 1/4"X15" | 14.20 |

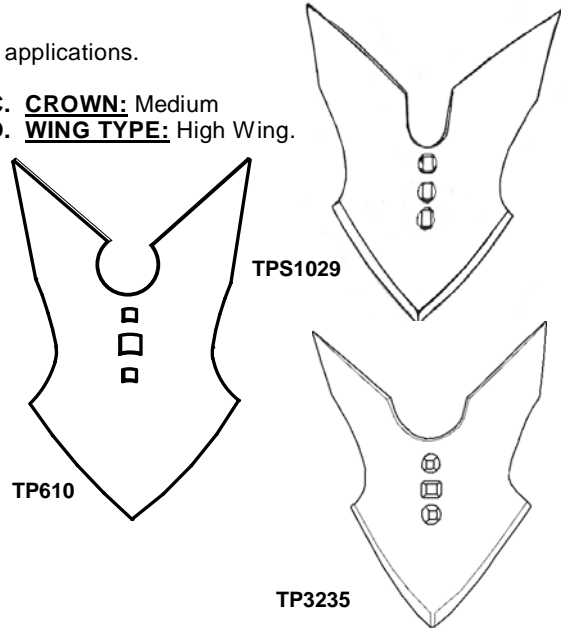

FURROWERS (HEAVY DUTY): High Crown furrowers for all crop applications.

A. HOLE PATTERN: Two holes, one slotted, for 1-1/4" to 2-1/4" centers for 7/16" plow bolt.

B. STEM:

- 1. TYPE:** NA
- 2. ANGLE:** NA

C. CROWN: High
D. WING TYPE: High Wing

| SIZE | PART # MACKAY/EMPIRE | WT |
|----------------|----------------------|-------|
| 1/4"X10" | TPH1110UB | 10.40 |
| 1/4"X12" | TPH1112UB | 11.30 |
| 1/4"X15" | TPH1115UB | 13.75 |
| 1/4"X18" | TPH1118UB | 16.25 |
| FURROWER POINT | | |
| 1/4"X3" | TPH1120UB | 2.08 |

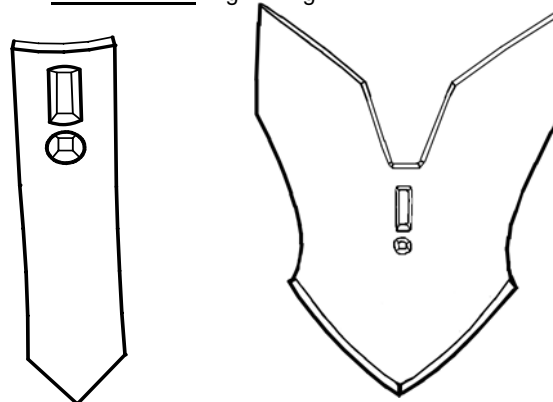

27 SERIES FURROWER:

A. HOLE PATTERN: Two holes, on 2-1/4" centers for 7/16" plow bolts and one square hole for 5/8" carriage bolt.

C. CROWN: High
D. WING TYPE: Medium Wing

| SIZE | PART # MACKAY/EMPIRE | WT |
|-----------|----------------------|------|
| 3/16"X6" | TPE27-306 | 3.01 |
| 3/16"X8" | TPE27-308 | 3.25 |
| 3/16"X10" | TPE27-310 | 3.74 |
| 3/16"X12" | TPE27-312 | 4.35 |
| SIZE | PART# PIPER | WT |
| 1/4"X6" | TPE27-406 | NA |
| 1/4"X8" | TPE27-408 | NA |
| 1/4"X10" | TPE27-410 | NA |
| 1/4"X12" | TPE27-412 | NA |

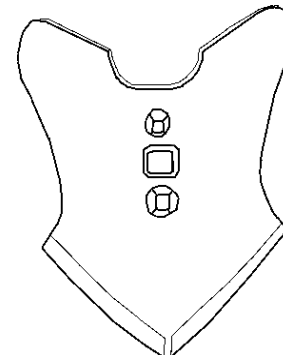

FURROWERS MAY BE ORDERED WITH THE FOLLOWING PREFIXES: (TP) PLAIN FURROW, (TH) HARD FACED FURROWER, (TC) CHROME INSERTED FURROWER.

TWISTED CHISEL POINTS FOR CHISEL PLOWS:

| SIZE | PART # | HOLE CENTER | BOLT SIZE | WT. |
|---------------|------------|---------------|-----------|------|
| 3/8" X3"X 22" | TP320-6LKS | 2 1/4"-2-1/2" | 1/2" | 7.85 |
| 3/8" X3"X 22" | TP320-6RKS | 2 1/4"-2-1/2" | 1/2" | 7.85 |

TWISTED SHOVELS HAVE 1/2" PLOW BOLTS HOLES ON 2-1/4"-2-1/2" CENTERS.



TWISTED SHOVELS MAY BE ORDERED WITH THE FOLLOWING PREFIXES:
(TP) PLAIN, (TH) HARDFACED, (TC) CHROME INSERTS.

SPRINGTOOTH POINT, FIELD CULTIVATOR POINTS, REVERSIBLE STEELS, CHISEL SPRINGTOOTH

| SIZE | PART # | HOLE CENTER | BOLT SIZE | WT. | TYPE |
|--|-------------|----------------|-----------|------|------|
| <u>SPRING TOOTH AND FIELD CULTIVATOR POINTS</u> | | | | | |
| 5/16" X 1-3/4" X 10" | TPAC-56 | 2" | 7/16" | 1.00 | H |
| 1/4"X1-3/4"X11" | TPDF-10 | 1-3/4" | 3/8" | .95 | H |
| 1/4"X1-3/4"X11" | TPDF-10UA | 1-1/4"-2-1/4" | 3/8" | .95 | H |
| 1/4"X1-3/4"X11" | TPDF-10UB | 1-1/4"-2-1/4" | 7/16" | .95 | H |
| 1/4"X1-3/4"X11" | TPDF-14 | 1-3/4" | 7/16" | .95 | H |
| 1/4"X2"X11" | TPDF-29 | 1-3/4" | 7/16" | 1.05 | H |
| 1/4"X1-3/4"X9" | TPDF-67 | JD Indents | 3/8" | .90 | B |
| 1/4"X1-3/4"X11" | TPDF010 | 1-3/4"-1-5/8" | 3/8" | .95 | G |
| 5/16"X1-3/4"X11" | TPDF010HD | 1-3/4"-1-5/8" | 3/8" | 1.05 | G |
| 1/4"X1-3/4"X9" | TPE79-402 | Single Hole | 3/8" | .92 | B |
| 1/4"X2"X9" | TPE79-403 | Single Hole | 3/8" | .95 | B |
| 5/16" X 1-1/2" X 10" | TPIF-10UB | 1-1/4"-2-1/4" | 7/16" | 1.12 | C |
| 5/16" X 2-1/2" X 10" | TPIF-110UB | 1-1/4"-2-1/4" | 7/16" | 1.64 | C |
| 3/8" X 1-1/2" X 10" | TPIF-1UB | 1-1/4"-2-1/4" | 7/16" | 1.44 | C |
| 5/16" X 2-1/2" X 10" | TPIF-210UB | 1-1/4"-2-1/4" | 7/16" | .95 | C |
| 3"X5/16"X10-1/2" | TPIF-310UB | 1-3/4" | 7/16" | 2.18 | C |
| 1/4"X1-3/4"X10" | TPST-19 | Strath. Nipple | 3/8" | .95 | A |
| <u>NON REVERSIBLE POINT</u> | | | | | |
| 2"X5/16"X9-1/2" | TPIF021 | 1-3/4" | 7/16" | 1.41 | E |
| <u>REVERSIBLE STEELS, ALFALFA SPIKES FOR COIL SHANKS AND CHISEL PLOWS</u> | | | | | |
| 1/4"X1-3/4"X11" | TP168UB | 1-1/4"-2 1/4" | 7/16" | 2.56 | C |
| 1/2"X2"X11" | TP169UB | 1-1/4"-2 1/4" | 7/16" | 2.85 | C |
| 5/8"X2"X13" | TP175-5C | 1-1/4" | 1/2" | 4.00 | D |
| 5/8"X2"X13" | TP175-9C | 2-1/4" | 1/2" | 4.00 | I |
| 1/2"X1-1/2X12" | TP75UB | 1-1/4"-2 1/4" | 7/16" | 1.75 | I |
| <u>CHISEL PLOW POINTS</u> | | | | | |
| 5/8"X2"X15" | TP182-9C | 2-1/4" | 1/2" | 4.90 | D |
| 5/8"X2"X15" | TP182-9 | 2-1/4" | 7/16" | 4.90 | D |
| 5/8"X2"X16" | TP21610HCKS | 2-1/4"-2-1/2" | 1/2" | 5.25 | D |
| 3/4"X2"X15" | TP83-9C | 2-1/4" | 1/2" | 4.80 | H |
| 3/4"X2"X15" | TP83-9D | 2-1/4" | 5/8" | 9.30 | H |
| 1"X2"X18" | TPHD-88 | 2-1/4"-2-1/2" | 1/2" | 9.30 | F |

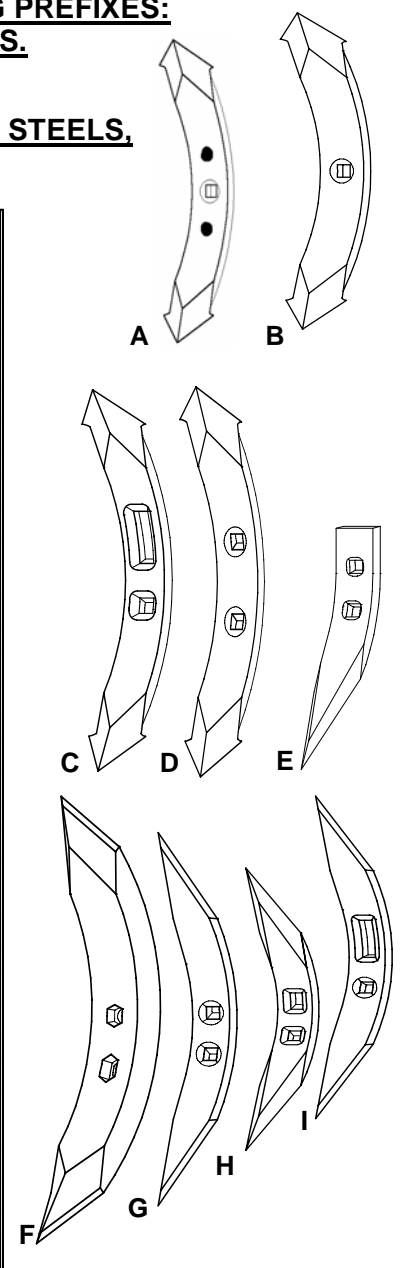

POINTS MAY BE ORDERED WITH THE FOLLOWING PREFIXES:
(TP) PLAIN, (TH) HARDFACED, (TC) CHROME INSERTS.

VEGETABLE KNIVES AND HOES

| SIZE | PART # | HOLE CENTER | BOLT SIZE | WT. |
|---|----------|-------------|-----------|------|
| CRESCENT HOLES | | | | |
| 1/4"X6" R. H. | TPS1016R | 1-1/4"-2" | 3/8" | 1.82 |
| 1/4"X6" L. H. | TPS1017L | 1-1/4"-2" | 3/8" | 1.82 |
| BEEET HOES | | | | |
| 3/16"X7" R. H. | TPS1002R | 1-1/4"-2" | 3/8" | 2.05 |
| 3/16"X7" L. H. | TPS1003L | 1-1/4"-2" | 3/8" | 2.05 |
| 3/16"X9" R. H. | TPS1004R | 1-1/4"-2" | 3/8" | 2.35 |
| 3/16"X9" L. H. | TPS1005L | 1-1/4"-2" | 3/8" | 2.35 |
| 1/4"X13" R. H. | TPS1006R | 1-1/4"-2" | 3/8" | 5.30 |
| 1/4"X13" L. H. | TPS1007L | 1-1/4"-2" | 3/8" | 5.30 |
| TENDER PLANT HOES | | | | |
| 3/16"X7" R. H. | TPS1122R | 1-1/4"-2" | 3/8" | 2.35 |
| 3/16"X7" L. H. | TPS1123L | 1-1/4"-2" | 3/8" | 2.35 |
| 3/16"X9" R. H. | TPS1124R | 1-1/4"-2" | 3/8" | 2.92 |
| 3/16"X9" L. H. | TPS1125L | 1-1/4"-2" | 3/8" | 2.92 |
| JOHNSON BED KNIVES (ONE PIECE) | | | | |
| 1/4"X8" R. H. | TPS4501R | 1-1/4"-2" | 3/8" | 3.75 |
| 1/4"X8" L. H. | TPS4500L | 1-1/4"-2" | 3/8" | 3.75 |
| JOHNSON BED KNIVES (WELDED TYPE) | | | | |
| 1/4"X6" R. H. | TPS1066R | 1-1/4"-2" | 3/8" | 3.25 |
| 1/4"X6" L. H. | TPS1066L | 1-1/4"-2" | 3/8" | 3.25 |

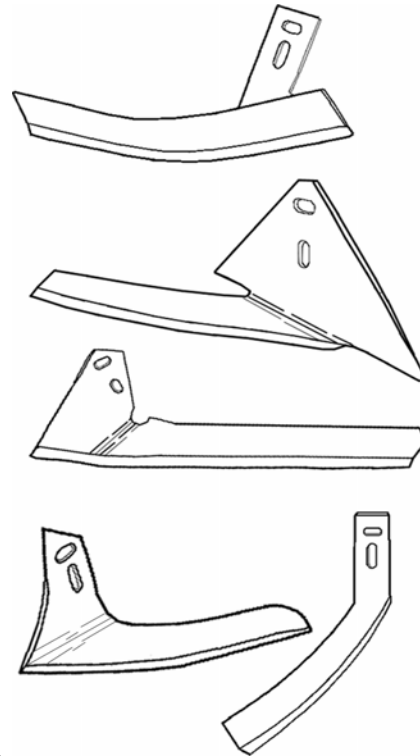

**KNIVES MAY BE ORDERED WITH THE FOLLOWING PREFIXES:
 (TP) PLAIN, (TH) HARDFACED, (TC) CHROME INSERTS.**

INJECTOR SHANKS

| PART # | DESCRIPTION | WT. |
|------------|---|------|
| SC-30 | 5/8" X 2" X 30" Plain injector shank | 7.8 |
| SC-N30 | 5/8" X 2" X 30" Injector shank with CJD20 bolt on high chrome alloy point. | 8 |
| SCH-N30 | 5/8" X 2" X 30" Injector shank with CJD20 bolt on high chrome alloy point and hard faced leading edge. | 8.25 |
| SC-34 | 3/4" X 2-1/2"X34" Plain injector shank | 8.30 |
| SC-N34 | 3/4" X 2-1/2"X34" Injector shank with CJD20 bolt on high chrome alloy point. | 8.50 |
| SCH-N34 | 3/4" X 2-1/2"X34" Injector shank with CJD20 bolt on high chrome alloy point and hardfaced leading edge. | 8.75 |
| SPT-1338 | 1" X 3"X 38" Bent shank W/Liquid tube plain. | 30.5 |
| SHT-1338 | 1" X 3"X 38" Bent shank W/Liquid tube & hardfaced. | 31 |
| SCT-1338 | 1" X 3" X 38" Bent shank with liquid tube and C20 chrome point. | 32.5 |
| S-130 | 1" X 3" Sundance shank only. | 24 |
| SC-SD130 | 1" X 3" Sundance shank with C1030 chrome shin guard. | 27 |
| SCP-SD130 | 1" X 3" Sundance shank with C1030 chrome shin guard and CD-830 high alloy chrome point. | 28.5 |
| SCP-SD3425 | 3/4" X2-1/2" Sundance shank beveled, hardfaced, and with CD-830 high chrome alloy point. | 29 |

For more information on chrome alloy applications, please refer to section 700-CHROME ALLOY.

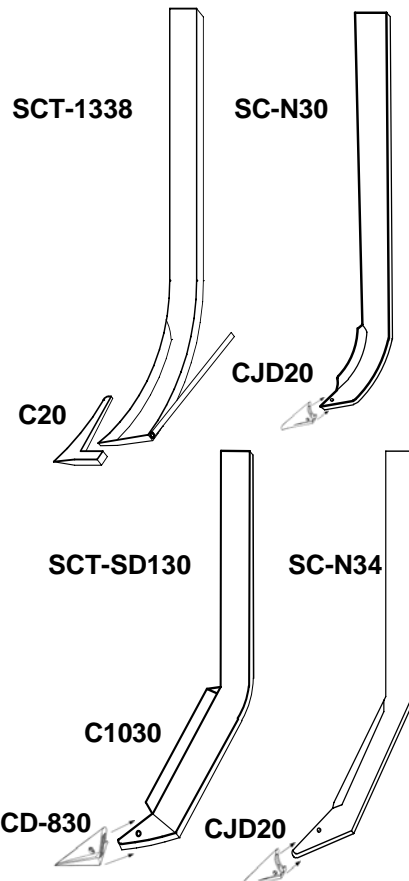

FACTORY AND NORWEST MFG. DRY AND LIQUID INJECTOR BLADES

NORWEST MANUFACTURED KNIVES ARE MADE FROM T-1 ALLOY STEEL, AND ONLY COME IN CHROME APPLICATIONS.

| PART # | DESCRIPTION | WT. |
|--|---|------|
| FACTORY BACK SWEEP INJECTOR KNIVES | | |
| KP130 | 13" back swept knife plain. | 3.00 |
| KH130 | 13" back swept knife hardfaced. | 3.45 |
| KP130T | 13" back swept knife with liquid tube plain. | 3.25 |
| KH130T | 13" back swept knife with liquid tube and hardfaced. | 3.65 |
| KP131T | 13"back swept knife with 1-1/4"Timik tube plain. | 3.95 |
| KH131T | 13"back swept knife with 1-1/4"Timik tube hardfaced | 4.15 |
| KP132T | 13" back swept knife with 2"fert. tube plain. | 4.10 |
| KH132T | 13"back swept knife with 2"fert. tube and hardfaced | 4.60 |
| NORWEST MANUFACTURED BACK SWEEP INJECTOR KNIVES | | |
| KCN130 | 13"back swept knife with C13 chrome edging. | 3.75 |
| KCN130T | 13"back swept knife with C13 chrome edging & liquid tube. | 4.00 |
| KCN130TC | 13" knife with C13 chrome edging, liquid tube, & CP13 curved chrome tube protector. | 4.50 |
| KCN131T | 13" knife with C13 chrome edging & 1-1/4"Timik tube. | 4.25 |
| KCN132T | 13" knife with C13 chrome edging & 2"fert. tube | 4.70 |
| FACTORY BACK SWEEP INJECTOR KNIVES | | |
| KP170 | 17" back swept knife plain. | 3.50 |
| KH170 | 17" back swept knife hardfaced. | 3.65 |
| KP170T | 17" back swept knife with liquid tube plain. | 3.85 |
| KH170T | 17" back swept knife with liquid tube and hardfaced. | 4.00 |
| NORWEST MANUFACTURED BACK SWEEP INJECTOR KNIVES | | |
| KCN170 | 17" knife with C13 chrome edging. | 4.25 |
| KCN170T | 17" knife with C13 chrome edging & liquid tube. | 4.35 |
| KCN170TC | 17" knife with C13 chrome edging, liquid tube, & CP13 curved chrome tube protector. | 4.50 |

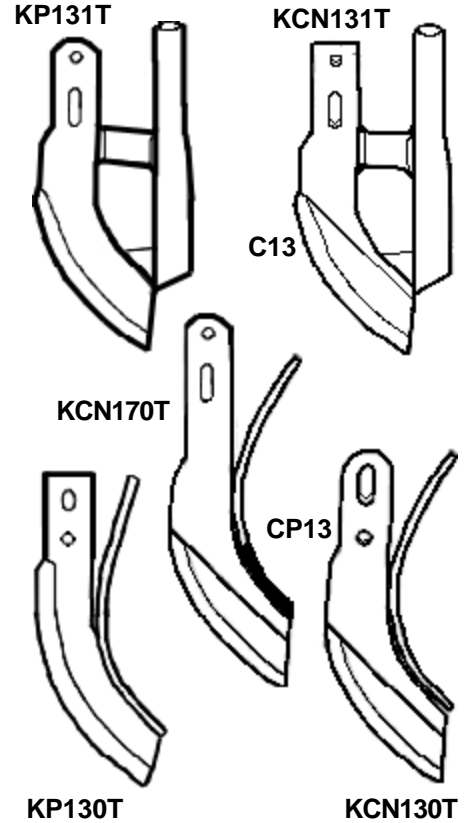

NORWEST FRONT SWEEP FERTILIZER INJECTOR KNIVES.

KP150 PARTS ARE DROP FORGED FOR THE LONGEST POSSIBLE WEAR.

| PART # | DESCRIPTION | WT. |
|--|---|------|
| FRONT SWEEP INJECTOR SHANKS | | |
| KCN140 | 17" knife with C20 chrome point and no tube. | 5.95 |
| KCN140T | 17" knife with C20 chrome point & liquid tube. | 6.20 |
| KCN140TC | 17" knife with C20 chrome point, liquid tube, & C15 straight chrome tube protector. | 6.45 |
| KCN142T | 17" knife with C20 chrome point & 2"fert. tube | 6.40 |
| KCN150T | 15" knife with C20 chrome point & liquid tube. | 5.60 |
| KCN150TC | 15" knife with C20 chrome point, liquid tube, & C15 straight chrome tube protector. | 5.96 |
| KCN152T | 15" knife with C20 chrome point & 2"fert. tube | 6.16 |
| For more information on chrome alloy applications, please refer to section 700-CHROME ALLOY. | | |

