

JACKS:

- ** A-FRAME**
- ** STEMS**
- ** SWIVEL**
- ** RACK**
- ** MARINE**
- ** ACCESSORIES**



BUTLER BUILT * BUTLER TOUGH

“QUALITY, PERFORMANCE AND DEPENDABILITY FOR 50 YEARS”

A-FRAME JACKS / JACK STEMS

Butler A-Frame Jacks feature a **QUICK DETACH SYSTEM** for attaching removable jack foot or caster assembly with either a Bolt or Universal Locking Pin.



*CASTER ASSEMBLIES

Available with either polyolefin or Industrial wheels. Please refer to the accessories section for more details.

*STANDARD FINISH

Zinc chromate on the inner tube and Gray powdercoat or royal zinc finish on the outer tube. Other finish options are available.

*SMOOTH CRANKING and LONG LIFE

Provided by HIGH STRENGTH ROLLED THREAD ACME SCREW, WELDED POSITIVE STOP and HEAVY DUTY THRUST BEARINGS.

*5,000 LB. JACKS

Feature HIGH CAPACITY SEALED THRUST BEARINGS, 1.33:1 REDUCTION GEAR SET and LONGER HANDLE for easier cranking.

2,250 LB. CAPACITY

PART #	MOUNT	HANDLE	TRAVEL	RETRACTED	EXTENDED
402527	A-FRAME JACK	TOPWIND	15"	8"	23"
402528	A-FRAME JACK	SIDEWIND	15"	8"	23"
402601	JACK STEM	TOPWIND	15"	22"	37"
402137	JACK STEM	SIDEWIND	15"	24"	39"
403151	A-FRAME JACK	TOPWIND	15"	4"	19"

5,000 LB. CAPACITY

PART #	MOUNT	HANDLE	TRAVEL	RETRACTED	EXTENDED
405149	A-FRAME JACK	TOPWIND	15"	8"	23"
405109	A-FRAME JACK	TOPWIND	15"	10"	25"
405150	A-FRAME JACK	SIDEWIND	15"	8"	23"
405108	A-FRAME JACK	SIDEWIND	15"	10"	25"
405522	JACK STEM	TOPWIND	10"	15"	25"
405138	JACK STEM	TOPWIND	15"	22"	37"
405521	JACK STEM	SIDEWIND	10"	17"	27"
405137	JACK STEM	SIDEWIND	15"	24"	39"



NOTE: ALL RETRACTED AND EXTENDED DIMENSIONS ARE MEASURED FROM MOUNTING PLATE TO GROUND ON A-FRAME JACKS AND FROM TOP OF JACK TO GROUND ON JACK STEMS. ADD 5 1/2" TO RETRACTED AND EXTENDED DIMENSIONS WHEN USING CASTER.

SWIVEL JACKS



***INNER & OUTER TUBES**

Engineered for strength and durability with a tube overlap at extension of 3" for 10" travel jacks and 5" for 15" travel jacks.

***STANDARD FINISH**

Zinc chromate on the inner tube and gray powder coat or royal zinc finish on the outer tube. Other finish options are available.

***WELDED FOOTPLATE**

4" x 7 1/2" on 2,250 lb. jacks, and 6" X 8" on 5,000 lb. jacks.

***FLANGE MOUNT**

Features single pull pin snap ring mount and flange plate on 2,250 lb. jacks. Double pull pin bolt on mount and flange plate on 5,000 lb. jacks.

***5,000 LB. JACKS**

Feature HIGH CAPACITY SOLID THRUST BEARINGS. 1.33:1 reduction gear set and LONGER HANDLE for easier cranking.

***TUBE MOUNT**

Features 360-degree seam welded tube with four 90 degree locking positions. Unique double lock hitch pin assembly includes 5/8" plated pin. Heavy duty 2" internal mounting tube is included.

2,250 LB. & 5,000 LB. CAPACITY

2,250 LB. PART #	5,000 LB. PART #	MOUNT	HANDLE	TRAVEL	RETRACTED	EXTENDED
402100	405100	FLANGE	TOPWIND	10"	11 7/8"	21 7/8"
402101	405101	FLANGE	TOPWIND	15"	14 7/8"	29 7/8"
402104	405104	FLANGE	SIDEWIND	10"	11 7/8"	21 7/8"
402105	405105	FLANGE	SIDEWIND	15"	14 7/8"	29 7/8"
402102	405102	TUBE	TOPWIND	10"	11 7/8"	21 7/8"
402103	405103	TUBE	TOPWIND	15"	14 7/8"	29 7/8"
402106	405106	TUBE	SIDEWIND	10"	11 7/8"	21 7/8"
402107	405107	TUBE	SIDEWIND	15"	14 7/8"	29 7/8"



***NOTE – ALL RETRACTED AND EXTENDED DIMENSIONS ARE MEASURED FROM CENTER OF MOUNTING PLATE/TUBE TO GROUND.**

RACK JACKS

FEATURES:

- *EXTRA HEAVY GAUGE D.O.M. TUBING to resist side thrust loads.
- *ONE PIECE SHAPER CUT RACK for smooth cranking.
- *Zinc chromate rack post for superior corrosion resistance.
- *Heavy Duty CAST STEEL GEAR BOX for maximum durability and side thrust capacity.
- *Slotted holes in gearbox base provide bolt-on or weld-on options.
- *HEAT TREATED WORM GEAR for increased strength and durability.
- *Easy access to internal gearbox components.
- *Oversized handle for easy gripping and cranking.
- *Industrial and polyolefin casters or foot options.



NOTE: All retracted and extended dimensions are measured from bottom of gearbox to ground.

PART #	DESCRIPTION	CAPACITY	TRAVEL	RETRACTED	EXTENDED
280603	RACK JACK A-FRAME GEAR BOX	1000 LBS.	NA	NA	NA
280059	RACK JACK W/INDUSTRIAL CASTER ASSEMBLY	1000 LBS.	17"	6"	23"
280060	RACK JACK W/POLY. CASTER ASSEMBLY	1000 LBS.	17"	6"	23"
280350	RACK JACK W/WELDED FOOT	1000 LBS.	17"	6"	23"

MARINE JACKS

FEATURES:

- *1.33:1 reduction gear set for easier cranking
- *Free rotating inner tube and oversized bearing for easy casting under heavy load.
- *Bolt on flange mount system eliminates snap ring.
- *Zinc chromate finish on all external parts for superior corrosion resistance.
- *Heavy-duty polyolefin wheels with reinforced axle bushings for increase wheel life.



NOTE: All retracted and extended dimensions are measured from top mounting hole to ground.

PART #	MOUNT	HANDLE	CAPACITY	TRAVEL	RETRACTED	EXTENDED
401321	SWIVEL FLANGE	SIDEWIND	1,250 LBS.	10"	14"	24"
401351	SWIVEL FLANGE	SIDEWIND	1,250 LBS.	15"	11"	26"
401348	FIXED	SIDEWIND	1,250 LBS.	15"	11"	26"



CAUTION: BUTLER'S JACKS ARE DESIGNED FOR THE SOLE PURPOSE OF RAISING AND LOWERING IMPLEMENT AND TRAILER TONGUES. BUTLER MUST APPROVE IN WRITING ANY OTHER TYPE OF APPLICATIONS PRIOR TO INSTALLATION. REMEMBER TO ALWAYS REPLACE COUPLERS, JACKS, OR HITCHBALLS WHICH LOOK WORN AND TO USE SAFETY CHAINS AT ALL TIMES. NEVER EXCEED THE RATED CAPACITY OF THE JACKS OR COUPLERS.



ACCESSORIES & REPLACEMENTS

POLYOLEFIN CASTER ASSEMBLIES



280063
RACK JACK



280065
SCREW JACK



280600
RACK JACK
BUTLER

INDUSTRIAL CASTER ASSEMBLIES



280062
RACK JACK



280064
SCREW JACK



280604
RACK JACK
BUTLER

SANDSHOE PLATES - DETACHABLE



280010
4" x 7 1/2"



320048
6" x 8"

SANDSHOE PLATES - WELD ON



350019
4" x 7 1/2"



350033
6" x 8"



100013
UNIVERSAL
LOCKING PIN



320015
5/8" HITCH
PIN W/CHAIN



200107
RETAINING RING
W/2 1/2" ID



350028
A-FRAME MOUNTING PLATE



350059
SUPPORT PLATE



050244
DELRIN
BUSHING



350030
2" O.D. INTERNAL
MOUNTING TUBE



350044
3" O.D. EXTERNAL
MOUNTING TUBE

MOUNTING KITS



280607
MARINE JACK MOUNTING
KIT FOR 401348 ONLY



280610
FLANGE MOUNTING KIT
(5,000 LB. JACK)



280606
FLANGE MOUNTING KIT
(2,000 LB. JACK)



200 SERIES
350032
FLANGE BRACKET
(500 SERIES - 35003)



NORWEST

MANUFACTURING INC.

71 SOUTH 215 WEST - RUPERT, ID 83350 - (208) 436-1770 FAX (208) 436-1776

7,000 lb. JACKS:

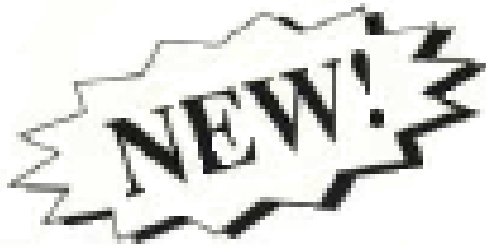

- **SIDEWIND**
- **TOPWIND**
- **DROP LEG**
- **CRANK ONLY**



BUTLER BUILT * BUTLER TOUGH

"QUALITY, PERFORMANCE AND DEPENDABILITY FOR 50 YEARS"

7,000 LB. JACKS

DESIGN FEATURES

*SIDEWIND OR TOPWIND MODELS WITH DROP LEG OR SCREW TRAVEL ONLY.

*LARGER 1" JACK SCREW AND BIGGER THRUST BEARING THAN COMPETITIVE MODELS

*HEAVY WALL OUTER (2 3/4" SQUARE) LARGEST MOUNTING SURFACE IN THE INDUSTRY

*RUGGED 6" x 8" SKID FOOT.

*ZINC PLATED INNER LEG AND DROP TUBE



JACKS SPECIFICATIONS

MODEL NO.	STATIC LOAD CAPACITY	DESCRIPTION	TRAVEL DISTANCE			UNIT WEIGHT	ADJUSTS
			DROP	SCREW	TOTAL		
407100	7,000 LBS.	TOPWIND FIXED/SCREW TRAVEL ONLY	NA	16"	15"	22.8" LBS	20.50 TO 36.50
407101	7,000 LBS.	TOPWIND DROP LEG JACK	13 1/2"	15"	28 1/2"	27.5" LBS.	23.0 TO 51.50
407102	7,000 LBS.	SIDEWIND FIXED/SCREW TRAVEL ONLY	NA	16"	15"	24.8" LBS	20.50 TO 36.50
407103	7,000 LBS.	SIDEWIND DROP LEG JACK	13 1/2"	15"	28 1/2"	28.9" LBS.	23.0 TO 51.50



NORWEST

MANUFACTURING INC.

71 SOUTH 215 WEST - RUPERT, ID 83350 - (208) 436-1770 FAX (208) 436-1776

HEAVY DUTY IMPLEMENT & TRAILER JACKS



BUTLER BUILT * BUTLER TOUGH

“QUALITY, PERFORMANCE AND DEPENDABILITY FOR 50 YEARS”



NORWEST MANUFACTURING INC.

71 SOUTH 215 WEST - RUPERT, ID 83350 - (208) 436-1770 FAX (208) 436-1776

HEAVY DUTY IMPLEMENT & TRAILER JACKS BUTLER BUILDS JACKS...THE BEST JACKS

For over 40 years Butler Products has worked to achieve one goal, to be the best jack manufacturer in the world. From 1,000 lbs. to 220,000 lbs. Whatever your application, Butler has your standard. High quality at a competitive price. Let Butler build your jack.



*Unsurpassed high strength 1 ½" dia.-4 threads per inch precision modified acme roll threaded jackscrew.

*ASTM A-500 top grade structural steel tubing.

*Solid steel nut completely welded to inner tubing for maximum side load and fore/aft stability while hooking and unhooking.

*High strength cast gears fastened to shaft with solid, hardened, alloy groove pins.

*Standard 8" X 11" base plate for greater stability.

*Field tested under rigorous conditions by quality ag implement manufacturers. Proven to withstand the highest side load and drawbar impact in the industry!

MODEL NO.	DESCRIPTION	CAPACITY (LBS.)	TRAVEL	OVERALL LENGTH RETRACTED	CLEARANCE TO BOTTOM OF CRANK RETRACTED	LENGTH TO CENTER OF MOUNTING RETRACTED	CRANKS PER 1" TRAVEL	OUTER TUBING SIZE	UNIT WEIGHT (LBS.)
83232	SIDEWIND TUBE MOUNT	12,000	13"	28 ½"		17 ½"	8 ½"	3 ½"	52
83230	SIDEWIND TUBE MOUNT	10,000	13"	28 ½"		17 ½"	8 ½"	3 ½"	44
82232	TOPWIND TUBE MOUNT	12,000	13"		32"	17 ½"	4	3 ½"	47
82230	TOPWIND TUBE MOUNT	10,000	13"		32"	17 ½"	4	3 ½"	38
82262	TOPWIND TUBE MOUNT	12,000	16"		35"	20 ½"	4	3 ½"	52
82260	TOPWIND TUBE MOUNT	10,000	16"		35"	20 ½"	4	3 ½"	43
82539	TOPWIND W/H.D. CASTER	10,000	13"		37 ½"	20 ½"	4	3 ½"	35
82330	TOPWIND DROP LEG	10,000	13**	25"			8 ½"	4"	54
83330	SIDEWIND DROP LEG	10,000	13**	25"			8 ½"	3 ½"	52
83332	SIDEWIND DROP LEG	10,000	13**	25"			8 ½"	4 ½"	62
83338	SIDEWIND DROP LEG	18,000	13**	25"			8 ½"	4 ½"	72



*ALL DROP LEGS HAVE AN ADDITIONAL 10" OF TRAVEL.
 ** HITCH PIN ASSEMBLIES AND IMPLEMENT TUBE MOUNTS AVAILABLE.
 **STANDARD CRANK RADIUS IS 11". OTHER SIZES FROM 7" TO 21" WELDED OR BOLT ON AVAILABLE.
 **VARIETY OF CAPACITY AND TRAVEL OPTIONS AVAILABLE.



NORWEST

MANUFACTURING INC.

71 SOUTH 215 WEST - RUPERT, ID 83350 - (208) 436-1770 FAX (208) 436-1776

STANDARD AND HEAVY-DUTY TRAILER JACKS

DROP LEG & SPRING LOADED JACKS

- *HORSE TRAILERS
- *GOOSENECK TRAILERS
- *REAR STABILIZERS FOR UTILITY, VAN AND STAKE BODY TRUCKS

STIFF LEG SUPPORTS

- *INDUSTRIAL TRAILERS
- *UTILITY TRAILERS
- *SPECIALTY TRAILERS

HEAVY DUTY LANDING GEAR

- *CONSTRUCTION TRAILERS
- *GRAIN TRAILERS
- *LIVESTOCK TRAILERS

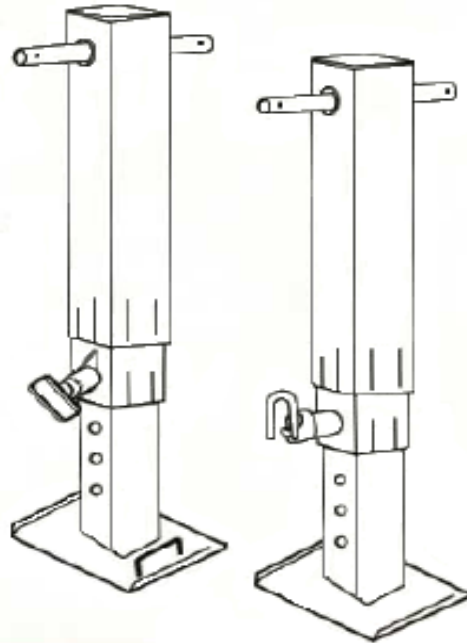

BUTLER BUILT * BUTLER TOUGH

“QUALITY, PERFORMANCE AND DEPENDABILITY FOR 50 YEARS”

DROP LEG JACKS – MODELS 22442 & 22482

The Little Giant series of drop leg jacks are designed with only the highest quality components to provide years of reliable service. Developed for gooseneck trailers, they are rugged units made from heavy duty materials and are easily installed on virtually any type of horse, utility or gooseneck trailer. They can also be used in pairs with a gear box assembly. These top quality drop leg jacks can also be used as rear stabilizers for van and stake body trucks.

- *4 ½" Heavy Wall Outer Tubing
- *1 ½" Diameter Rolled Thread Jackscrew
- *Solid Steel Jackscrew Nut
- *Self Lubricating Thrust Bearing for Efficient Lifting
- *Precision Cast Gears
- *Spring Loaded Poppet Assembly for Easy Drop Leg Operation
- *Lift Handle on Full 10" X 12" Base
- *All Models INCLUDE Crank Handle

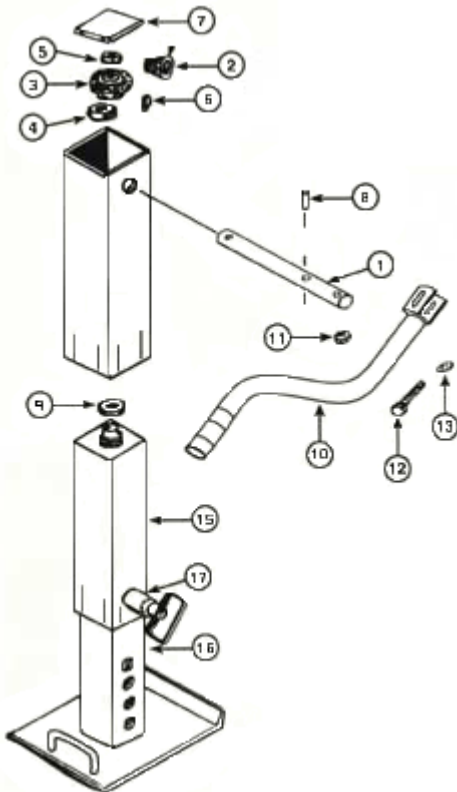
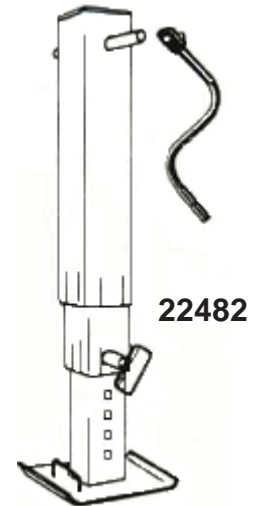
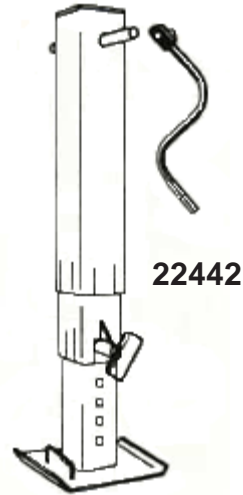

BUTLER LITTLE GIANT #22442 & 22482 REPLACEMENT PARTS

INDEX	DESCRIPTION	PART #
1	CROSS SHAFT	2H-60001
2	PINION GEAR	10-50058
3	BEVEL GEAR	10-50057
4	BUSHING	10-70006
5	LOCK NUT	10-80028
6	KEY	10-80001
7	COVER	20-20028
8	GROOVE PIN	10-80147
9	THRUST BEARING	10-80012
10	CRANK ASSEMBLY	20-99029
11	CRANK NUT 3/8" x 16 HEX	10-80089
12	CRANK BOLT 3/8" x 16 x 2 ¼"	10-80085
13	CRANK WASHER 3/8" STANDARD	10-80004
14	OUTER LEG ASSEMBLY	2H-20502
15	INNER LEG ASSEMBLY (22442)	2H-30013
15	INNER LEG ASSEMBLY (22482)	2H-30015
15	INNER LEG ASSEMBLY (22442RS)	2H-30011
16	DROP LEG ASSEMBLY (22442)	2H-30014
16	DROP LEG ASSEMBLY (22482)	2H-30016
16	DROP LEG ASSEMBLY (22442RS)	2H-30017
17	POPPET ASSEMBLY	PA-22442 PA-22482
18	POPPET ASSEMBLY (RS) (NOT SHOWN)	RSPA-442
19	RETURN SPRING (NOT SHOWN)	RS-HTD

DROP LEG LANDING GEAR

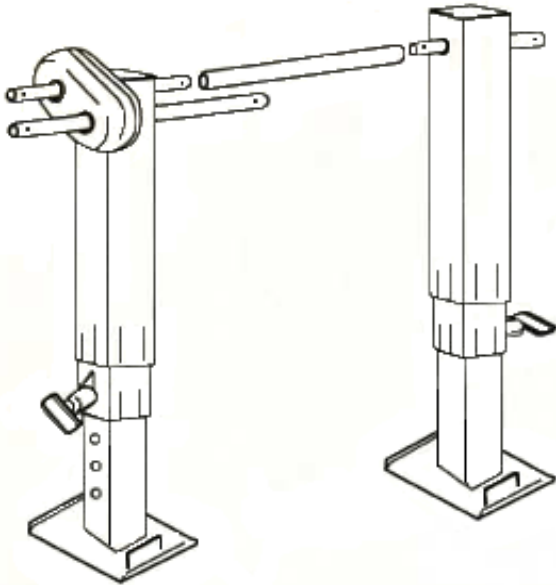

LG 482

TRUCKS

- *VAN BODIES
- *STAKE BODIES
- *UTILITY TRUCKS
- *CRANE BODIES

ADDITIONAL USES

- *TIRE REPAIR & ROTATION
- *REAR END MAINTENANCE
- *DOCK HEIGHT ADJUSTMENT
- *FORK LIFT SUPPORT



22482 G

2 SPEED MODELS
 GREATER LIFT CAPACITY
 FASTER & EASIER CRANKING

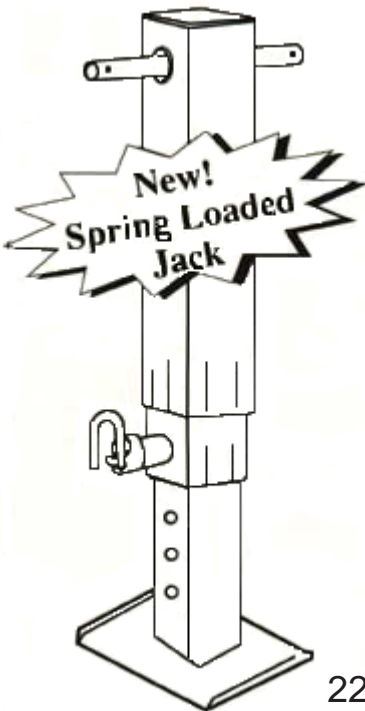

22442 RS

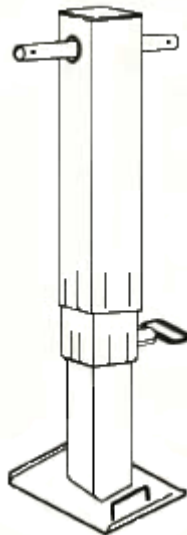

22442

TRAILERS

- *GOOSENECKS
- *HOT SHOTS
- *MINIS
- *LIVESTOCK
- *UTILITY
- *LOW PROFILE
- *CUSTOM
- *CONSTRUCTION

...AND MUCH MORE

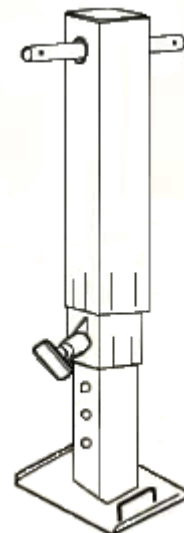

22482



NORWEST MANUFACTURING INC.

71 SOUTH 215 WEST - RUPERT, ID 83350 - (208) 436-1770 FAX (208) 436-1776

HEAVY-DUTY TRAILER JACKS

Models: 22444, 22444G, 22535, 22550

These supports are designed for a wide variety of trailers requiring greater capacity for heavier loads.

Single Speed
Model 22444

Two Speed
Model 22444G

Stiff Leg Supports
Models 22535 and 22550

All Jacks and Stiff Legs
can be used individually
or in pairs.

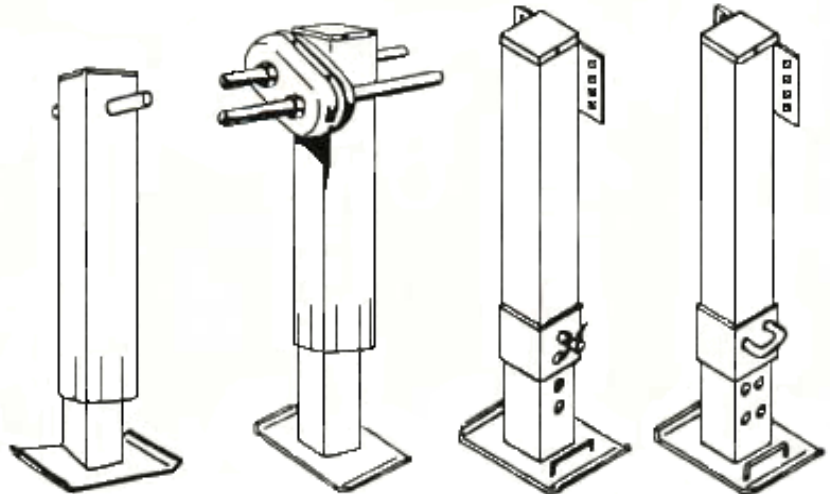

22444

22444G

22535

22550

JACKS SPECIFICATIONS

MODEL	STATIC LOAD CAPACITY	LIFT CAPACITY	RETRACTED LENGTH	EXTENDED LENGTH	TRAVEL DISTANCE			UNIT WEIGHT	CRANK TURNS PER 1" OF TRAVEL	
					DROP	SCREW	TOTAL		HIGH GEAR	LOW GEAR
22442	12,000	10,000	25"	47 1/2"	10"	12 1/2"	22 1/2"	62 LBS.	8 1/2	N/A
22482	18,000	10,000	25"	47 1/2"	10"	12 1/2"	22 1/2"	72 LBS.	8 1/2	N/A
22442G	12,000	12,000	25"	47 1/2"	10"	12 1/2"	22 1/2"	82 LBS.	3 1/2	26
22482G	18,000	18,000	25"	47 1/2"	10"	12 1/2"	22 1/2"	92 LBS.	3 1/2	26
LG 442	24,000	24,000	25"	47 1/2"	10"	12 1/2"	22 1/2"	150 LBS.	3 1/2	26
LG 482	36,000	36,000	25"	47 1/2"	10"	12 1/2"	22 1/2"	170 LBS.	3 1/2	26
22444	25,000	10,000	27 15/16"	44 7/16"	N/A	16 1/2"	16 1/2"	63 LBS.	8 1/2	N/A
22444G	25,000	25,000	27 15/16"	44 7/16"	N/A	16 1/2"	16 1/2"	83 LBS.	3 1/2	26
22535	35,000	N/A	30 3/8"	49 7/8"	19 1/2"	N/A	19 1/2"	52 LBS.	N/A	N/A
22550	50,000	N/A	30 3/8"	49 7/8"	19 1/2"	N/A	19 1/2"	55 LBS.	N/A	N/A



NORWEST

MANUFACTURING INC.

71 SOUTH 215 WEST - RUPERT, ID 83350 - (208) 436-1770 FAX (208) 436-1776

HEAVY-DUTY COUPLERS





BUTLER BUILT * BUTLER TOUGH

“QUALITY, PERFORMANCE AND DEPENDABILITY FOR 50 YEARS”

THE INDUSTRY STANDARD IN QUALITY

Each Butler coupler is manufactured with **INVESTMENT CAST HEADS** and **PRECISION MACHINED COLLARS** that tightly hold the locking jaw. All coupler **HEADS** and **COLLARS** are **HEAT TREATED** for **SUPERIOR STRENGTH** and **DURABILITY**.

	<p>A-FRAME *Fits Standard 50 degree Tongue *Reinforced for Extra Strength *Accepts Screw Jacks or Rack Jacks *Tapped Holes for Jack Mounting</p>			
	<p>STRAIGHT TONGUE SQUARE *Bolt On or Weld On *Fits 3" Square Tube or 3" Channel</p>		<p>STRAIGHT TONGUE SQUARE *Weld On *Fits 3" Square Tube or 3" Channel *With or Without Latch</p>	
	<p>PIPE MOUNT *Weld On *2 1/4" Outside Diameter *1 3/4" Inside Diameter</p>		<p>PIPE MOUNT *Without Latch *Weld On *2 1/2" Outside Diameter *1 3/4" Inside Diameter</p>	

COUPLER STYLE	BUTLER PART NO.	BALL SIZE	MAX TRAILER WEIGHT	MAX VERTICAL TONGUE LOAD	SAE CLASS
A-FRAME	290006	2"	5,000 LBS.	750 LBS.	3
	290032	2"	7,000 LBS.	750 LBS.	4
	290025	2 5/16"	12,500 LBS.	1,875 LBS.	4
STRAIGHT TONGUE SQUARE	290008	2"	5,000 LBS.	750 LBS.	3
	290033	2"	7,000 LBS.	750 LBS.	4
	290027	2 5/16"	12,500 LBS.	1,875 LBS.	4
	*290044	2"	5,000 LBS.	750 LBS.	3
PIPE MOUNT	290035	2"	5,000 LBS.	750 LBS.	3
	**290042	2"	5,000 LBS.	750 LBS.	3
	290036	2"	7,000 LBS.	750 LBS.	4
	**290046	2"	7,000 LBS.	750 LBS.	4
	290037	2 5/16"	12,500 LBS.	1,875 LBS.	4
	**290045	2 5/16"	12,500 LBS.	1,875 LBS.	4
STRAIGHT TONGUE ROUND	290007	2"	5,000 LBS.	750 LBS.	3
	290038	2"	7,000 LBS.	750 LBS.	4
	290039	2 5/16"	12,500 LBS.	1,875 LBS.	4

*BOLT ON

**WITHOUT LATCH

CAUTION: THE ABOVE COUPLERS MUST BE USED WITH THE PROPER DIAMETER HITCHBALL AS INDICATED. THE COUPLER MUST BE PROPERLY LOCKED AND THE SAFETY LOCKING PIN MUST BE INSTALLED BEFORE TOWING. FAILURE TO DO SO IS EXTREMELY DANGEROUS AND MAY RESULT IN THE UNCOUPLING OF THE TRAILER. ALWAYS USE SAFETY CHAINS. DO NOT EXCEED THE MAXIMUM GROSS VEHICLE RATING OF THE COUPLER BALL OR TRAILER – WHICHEVER IS LESS.