



NORWEST

MANUFACTURING

71 SOUTH 215 WEST-RUPERT, ID- PHONE: (208) 436-1770 - FAX: (208) 436-1776

SECTION 200 -60 A-FRAMES & TOOL BAR SPACERS

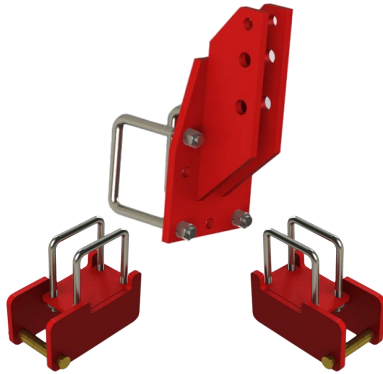

3 PIECE A-FRAMES

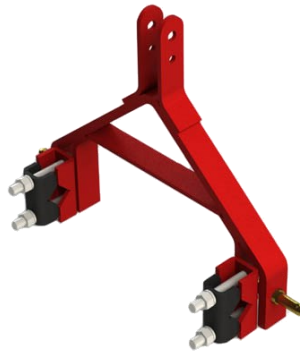

1 PIECE A-FRAMES



QUICK HITCHES

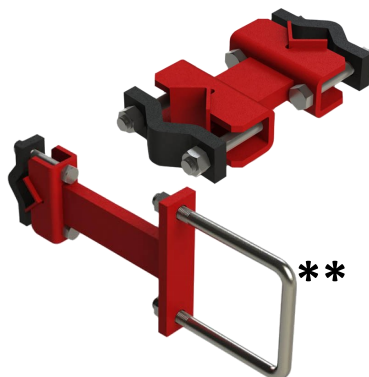

TOOL BAR SPACERS

** Select Tool Bar Spacers may be ordered in Custom Sizes.

Call Norwest Mfg. for Details 208-436-1770

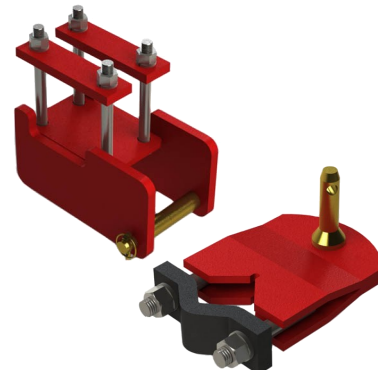





LIFT BRACKETS

A-FRAMES

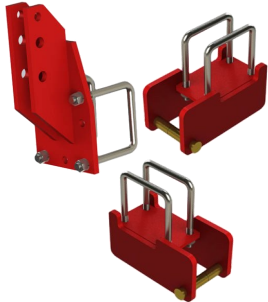

CATEGORY II & III A-FRAME TABLE

Vert. (A)	Horiz.(B)					
(A)	(B)	COMPLETE HITCH PART NUMBER	CENTER MAST COMPLETE W/BOLTS	CENTER MAST BODY ONLY	LIFT BRACKET COMPLETE W/ BOLTS & PINS	LIFT BRACKET BODY ONLY
BAR SIZE						
4"	4"	AH3-44	AH3-4C	Z-AH3-4C	AH3-4B	Z-AH3-4B
4"	6"	AH3-46	AH3-46C	Z-AH3-4C	AH3-46B	Z-AH3-6B
5"	7"	AH3-57	AH3-5C	Z-AH3-4C	AH3-57B	Z-AH3-7B
6"	6"	AH3-66	AH3-6C	Z-AH3-4C	AH3-6B	Z-AH3-6B
6"	8"	AH3-68	AH3-68C	Z-AH3-4C	AH3-68B	Z-AH3-8B
7"	5"	AH3-75	AH3-75C	Z-AH3-4C	AH3-5B	Z-AH3-5B
7"	7"	AH3-77	AH3-7C	Z-AH3-4C	AH3-7B	AH3-7B
7"	7"					
Special Cultivator Hitch with Open Center		AH3-77CUL*	AH3-7CH	Z-AH3-7CUL	AH3-7B	Z-AH3-7B

www.norwest-mfg.com

*AH3-77CUL is designed specifically for the Norwest Spider Cultivator. Not available for other applications.

THREE PIECE HEAVY DUTY A-FRAMES FOR TOOL BARS

3 Piece A-Frames made by Norwest are some of the best aftermarket frames made. They are "Quick Hitch Ready" for Category 2 & 3.

3 Piece A-Frames include Center Mast, Lift Brackets, and Lift Pins ready to attach to Bar.
Top Link Pins Not Included.

**

The first number after the dash in part number is the **Vertical Measurement**.
The second number is the **Horizontal Measurement**.
Example: AH3-46 = AH3-4(V)6(H)

CATEGORY II & III A-FRAME TABLE

Mounting Hardware



TOOL BAR SIZE (Cont. from page 200-602)	U-BOLTS USED		HEX BOLTS USED		NUT	LOCK WASHER	STRAP	LIFT PIN	LYNCH PIN	BUSHING
	CENTER MAST	LIFT BRACKET	CENTER MAST	LIFT BRACKET						
4" x 4"	FUB4060-78	FUB4060-78	n/a	n/a	FHN78	FLW78	n/a	21293	21938	21197
4" x 6"	n/a	n/a	FHB78900G5	FHB78700G5	FHN78	FLW78	40S	21293	21938	21197
5" x 7"	n/a	16-00204	FHB781000G5	n/a	FHN78	FLW78	50S	21293	21938	21197
6" x 6"	n/a	n/a	FHB78900G5	FHB78900G5	FHN78	FLW78	60S	21293	21938	21197
6" x 8"	n/a	n/a	FHB78900G5	FHB78900G5	FHN78	FLW78	60S	21293	21938	21197
7" x 5"	16-00204	n/a	n/a	FHB781000G5	FHN78	FLW78	50S	21293	21938	21197
7" x 7"	16-03204	16-03204	n/a	n/a	FHN78	FLW78	n/a	21293	21938	21197
7" x 7" Special Cultivator Hitch with Open Center	n/a	16-03204	FHB781000G5	n/a	FHN78	FLW78	n/a	21293	21938	21197

www.norwest-mfg.com

*AH3-7CH is designed specifically for the Norwest Spider Cultivator. Not available for other applications.



A-FRAMES

ONE PIECE A-FRAMES FOR 2-1/4" DIAMOND BARS

All A-Frames come ready to attach to tool bar with lift pins. *Top Link Pins Not Included.*

LIGHT DUTY CATEGORY I A-FRAMES

PART NUMBER	CATEGORY	PIN DIAMETER	Lift Pin Meas. (A) (Center to Center)	WEIGHT (LBS.)	TOOL BAR STRAP
AL-1D	I - Light Duty	7/8"	26"	55	342S



STANDARD & HEAVY DUTY CATEGORY I A-FRAMES

PART NUMBER	CATEGORY	PIN DIAMETER	PART NUMBER	Lift Pin Meas. (A) (Center to Center)	WEIGHT (LBS.)	TOOL BAR STRAP
AS-1D	I - Standard Duty	7/8"	21226	31-5/8"	68	342S
AH-1D	I - Heavy Duty	7/8"	21226	31-5/8"	110	342S
AH-1BD	I - Heavy Duty w/Brace	7/8"	21226	31-5/8"	133	706

STANDARD & HEAVY DUTY CATEGORY II A-FRAMES

PART NUMBER	CATEGORY	PIN DIAMETER	PART NUMBER	Lift Pin Meas. (A) (Center to Center)	WEIGHT (LBS.)	TOOL BAR CAP
AS-2D	II - Standard Duty	1-1/8"	21242	37"	86	706
AS-2BD	II - Standard Duty w/Brace	1-1/8"	21242	37-1/8"	129	706
AS-QH2D	II - Will Fit Quick Hitches	1-1/8"	21242	37"	107	706
AH-UH2D	II - Extra Heavy Duty Under Slung	1-1/8"	21242	36-1/4"	112	710

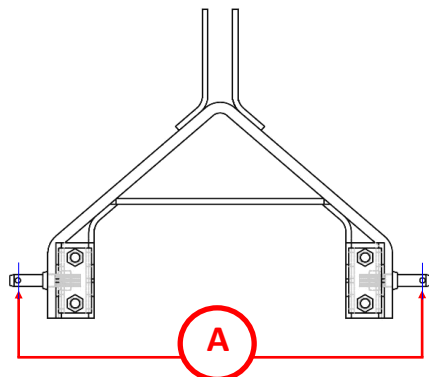
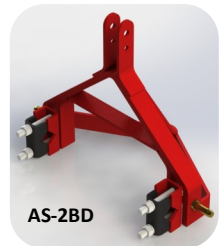
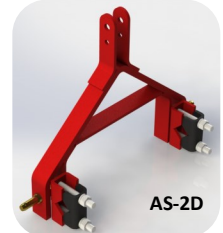

A-FRAMES



THREE PIECE A-FRAMES FOR 2-1/4" DIAMOND BARS

3 Piece A-Frames include Center Mast, Lift Brackets, and Lift Pins ready to attach to Bar.

Top Link Pins Not Included.

CATEGORY I & II A-FRAMES

COMPLETE HITCH PART NUMBER	CATEGORY	PIN DIAMETER	LIFT PIN PART NUMBER	CENTER MAST PART NUMBER	BAR STRAP	LIFT BRACKET PART NUMBER	BAR STRAP
AS3-1D	CAT I	7/8"	21226	AS3-1DC	342S	AS3B-1D	342S
AS3-2D	CAT II	1-1/8"	21242	AS3-2DC	130S	AS3B-2D	130S

ALL 3PIECE A-FRAMES FOR TOOL BARS COME WITH BUSHINGS.

A-FRAMES ARE CATEGORIZED BY THE BUSHING AS FOLLOWS: **CATEGORY II** - WITHOUT BUSHING
CATEGORY III - WITH BUSHING

QUICK HITCHES

SpeCo Quick Hitches are a popular device that make the attachment and release of 3-point implements fast and easy.

Available in Category I, II, and III.



AQH-2S

CATEGORY I, II & III QUICK HITCHES							
PART NUMBER	CATEGORY	PIN DIAMETER	Meas. (A) (Center to Center)	MAX RECOMMENDED HP		WEIGHT (LBS.)	
AQH-1E	I - Standard Duty	3/4"	28-1/4"	40		70	
AQH-2E	II - Standard Duty	1"	34-1/2"	60		134	
AQH-1S	I - Standard Duty	7/8"	27-1/4"	50		76	
AQH-2S	II - Standard Duty	1-1/8"	32"	100		134	
AQH-2H	II - Heavy Duty	1-1/8"	32"	150		160	
AQH-23S	II & III - Standard Duty	1-7/16"	38"	225		196	
AQH-3S	III - Standard Duty	1-7/16"	38"	225		182	
AQH-3N	III - Narrow Heavy Duty	1-7/16"	32"	225		176	

TRACTOR CATEGORIES	TRACTOR POWER	TOP LINK PIN DIAMETER		LIFT ARM PIN DIAMETER			
		HORSE POWER	kW	SAE	METRIC	SAE	METRIC
CAT 0	Category 0	Up to 20	<15	5/8"	15.8 mm	5/8"	15.8 mm
CAT 1	Category 1	20 - 45	15 - 35	3/4"	19 mm	7/8"	22.4 mm
CAT 2	Category 2	40 - 80	30 - 75	1"	25.4 mm	1-1/8"	28.7 mm
CAT 3	Category 3	80 - 225	60 - 168	1-1/4"	31.8 mm	1-7/16"	37.4 mm
CAT 4	Category 4	180 - 400	135 - 300	1-3/4"	44.5 mm	2"	50.8 mm

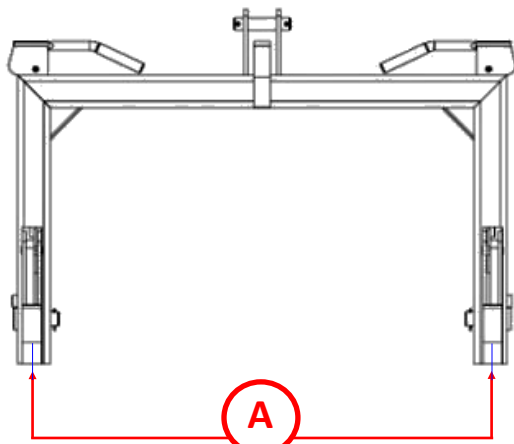

3-Point Tools 200-606

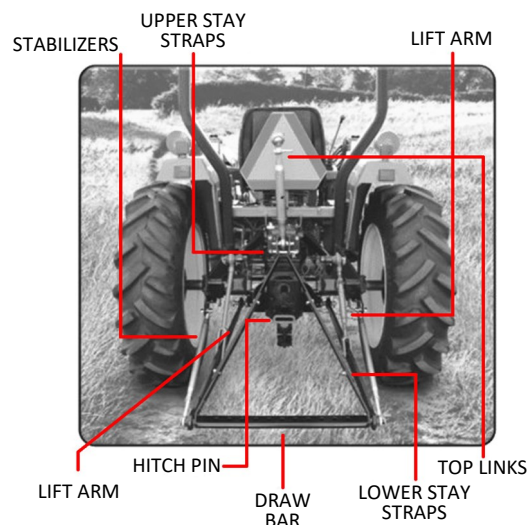

TOOL BAR SPACERS

TOOL BAR SPACERS (SPREADER BARS)

2-1/4" \diamond to 2-1/4" \diamond

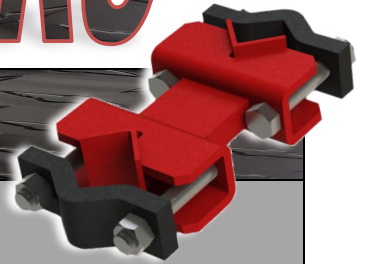



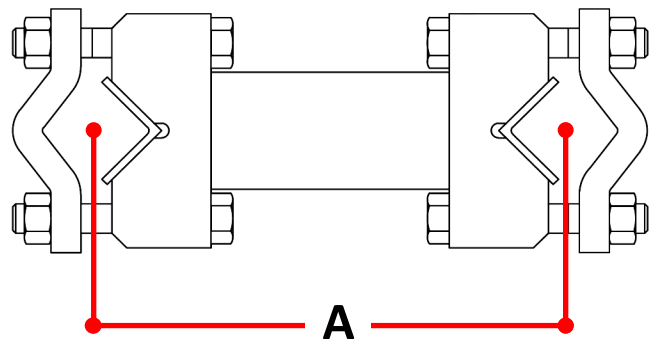
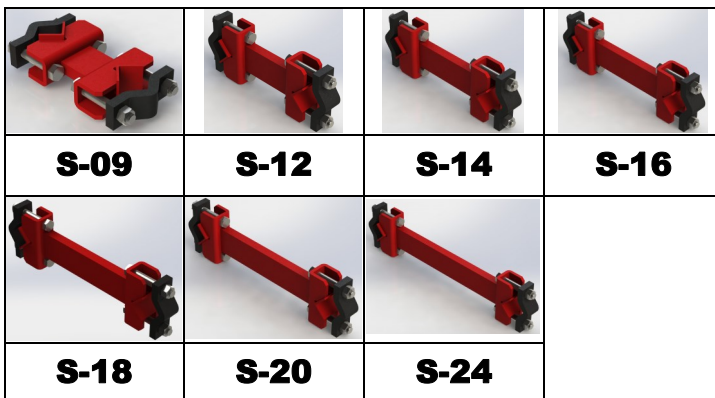

COMPLETE PART NUMBER	PART NUMBER (BODY ONLY)	PART NUMBER (STRAP ONLY)	BOLTS	NUTS	MATERIAL	CENTERS (MEAS. A)	WEIGHT
S-09	BS09	342S	FHB34500G5 3/4" X 5"	FHN34	1" X 3" FLAT BAR	9"	20 LBS.
S-12	BS12	342S	FHB34500G5 3/4" X 5"	FHN34	1" X 3" FLAT BAR	12"	23 LBS.
S-14	BS14	342S	FHB34500G5 3/4" X 5"	FHN34	1" X 3" FLAT BAR	14"	25 LBS.
S-16	BS16	342S	FHB34500G5 3/4" X 5"	FHN34	1" X 3" FLAT BAR	16"	27 LBS.
S-18	BS18	342S	FHB34500G5 3/4" X 5"	FHN34	1" X 3" FLAT BAR	18"	28 LBS.
S-20	BS20	342S	FHB34500G5 3/4" X 5"	FHN34	1" X 3" FLAT BAR	20"	29 LBS.
S-24	BS24	342S	FHB34500G5 3/4" X 5"	FHN34	1" X 3" FLAT BAR	24"	34 LBS.



CUSTOM TOOL BAR SPACERS

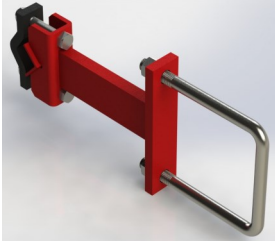



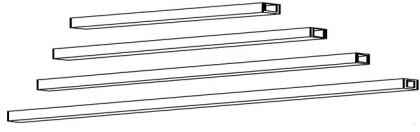

TOOL BAR SPACERS (SPREADER BARS)

2-1/4" \diamond to FLAT TOOL BARS

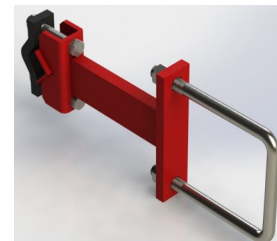
					
	2-1/4" \diamond BAR INFORMATION			TOOL BAR INFORMATION	
COMPLETE PART NUMBER	PART NUMBER 2-1/4" \diamond STRAP	HEX BOLT	NUT	BAR SIZE	
S-2540	342S	FHB34500G5 3/4" X 5" BOLT	FHN34	4"	4"
				4"	6"
S-2560	342S	FHB34500G5 3/4" X 5" BOLT	FHN34	6"	6"
				6"	8"
S-2570	342S	FHB34500G5 3/4" X 5" BOLT	FHN34	7"	5"
				7"	7"

TOOL BAR SPACERS (SPREADER BARS)

2-1/4" \diamond to FLAT TOOL BARS

					
	TOOL BAR INFORMATION				
COMPLETE PART NUMBER	U-BOLTS / HEX BOLTS	NUT	LOCK WASHER	PART NUMBER TOOL BAR STRAP	
S-2540	FUB4060-78 U-BOLT for 4" x 4" Tool Bar	FHN78	FLW78	n/a	
	FHB78900G5 HEX BOLT for 4" x 6" Tool Bar	FHN78	FLW78	60S	
S-2560	FHB78900G5 HEX BOLT for 6" x 6" Tool Bar	FHN78	FLW78	60S	
	FHB78900G5 HEX BOLT for 6" x 8" Tool Bar	FHN78	FLW78	60S	
S-2570	16-00204 U-BOLT for 7" x 5" Tool Bar	FHN78	FLW78	n/a	
	16-03204 U-BOLT for 7" x 7" Tool Bar	FHN78	FLW78	n/a	

www.norwest-mfg.com

Prices are based on 9" - 16" Tool Bar Spacers. Longer bar spacers will incur a higher price.



NORWEST

MANUFACTURING

71 SOUTH 215 WEST-RUPERT, ID- PHONE: (208) 436-1770 - FAX: (208) 436-1776



Remember, When giving toolbar measurements, Norwest requests the Vertical Measurement first , followed by Horizontal Measurement.

Please have measurements and other information ready prior to placing your order.

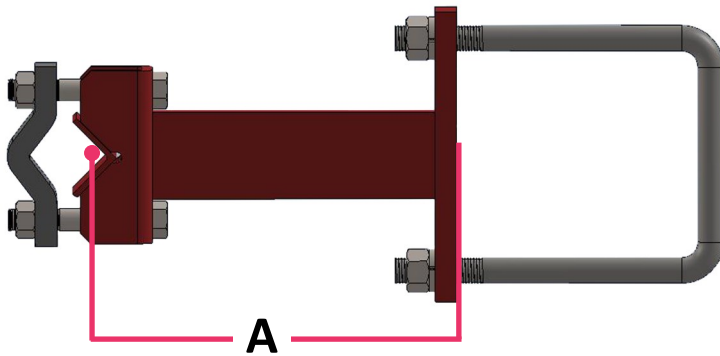
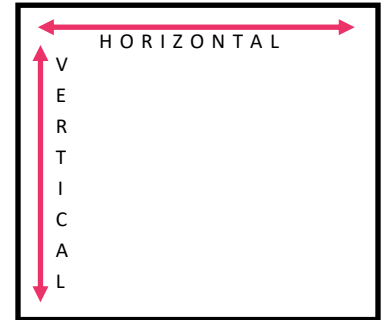

To determine Bar Spacer Size for all custom tool bar spacers, Please refer to the drawing at **Left**.

Measurement (A) should be taken from the **Corner of the 2-1/4" Diamond Tool Bar to the edge of the Square Tool Bar.**



*Other Custom Tool Bar Spacers Available.
Please call Norwest for details.*

(208) 436-1770

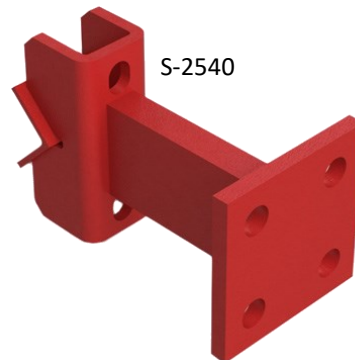

S-2540

Bar Spacer Body for:

4" x 4" & 4" x 6"
Tool Bars

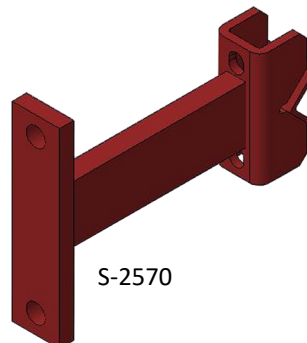

S-2570

Bar Spacer Body for:

6" x 6", 6" x 8", 7" x 5" & 7" x 7"
Tool Bars

www.norwest-mfg.com