



NORWEST

MANUFACTURING

71 SOUTH 215 WEST-RUPERT, ID- PHONE: (208) 436-1770 - FAX: (208) 436-1776

SECTION 600 - A

RIPPER POINTS



BIG ED



BIG OX



**BRENT / CPC /
UNVERFERTH**



BRILLION



SUB-SOILER POINT OPTIONS

	PLAIN	CHROME IN-SERT	CHROME & GUSSET	PENETRATOR (IH) CHROME
--	-------	----------------	-----------------	------------------------

***Pictures are for Illustration Only. Actual Part May Not Look Exactly the Same.**



TO FIT		<i>RP21507 Shown</i>	<i>RCHJ21507 Shown</i>	<i>RCHJ21507G Shown</i>	<i>RCHJ21507IH Shown</i>
--------	--	----------------------	------------------------	-------------------------	--------------------------

BIG ED <i>1" SHANKS</i>		RPB3420	RCHB3420	N/A	N/A
BIG ED <i>1-1/4" SHANKS</i>		RPB1020	RCHS1020	N/A	N/A
BIG OX		RP2D-5	RCH2D-5	N/A	N/A
BRENT/CPC/ UNVERFERTH <i>1-1/4" SHANKS</i>		RPHU1025	RCHU1025	RCHU1025G	RCHU1025IH
BRILLION <i>1" SHANKS</i>		RPB2509B2	RCHB2509B2	RCHB2509B2G	N/A
BRILLION <i>1-1/4" SHANKS</i>		RPB2510B2	RCHB2510B2	RCHB2510B2G	N/A

PENETRATOR (IH) CHROME & GUSSET	WINGS	SHARK FIN	SHARK FIN & GUSSET
			
<i>RCHJ21507IHG Shown</i>	<i>RCWU1025 Shown</i>	<i>RCSJ21507 Shown</i>	<i>RCSJ21507G Shown</i>
N/A	N/A	N/A	N/A
N/A	N/A	N/A	N/A
N/A	N/A	N/A	N/A
RCHU1025IHG	RCWU1025	N/A	N/A
N/A	N/A	N/A	N/A
N/A	RCWB2510B2 (w/ 7" Wings) RCWB2510B2G (w/ Gusset) RCWB2510B2G15 (15" Wings w/ Gusset) RCWB2510B2G15L (Left Wing Only) RCWB2510B2g15R (Right Wing Only)	RCSB2510B2	RCSB2510B2G



NORWEST

M A N U F A C T U R I N G

71 SOUTH 215 WEST-RUPERT, ID- PHONE: (208) 436-1770 - FAX: (208) 436-1776

SECTION 600 - B

RIPPER POINTS



CASE/IH



DMI: TIGER

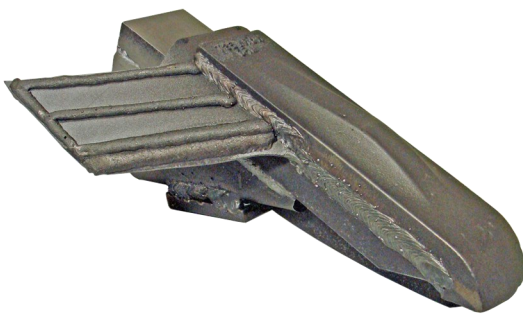

DMI / KRAUSE / GREAT PLAINS





SUB-SOILER POINT OPTIONS



NORWEST MANUFACTURING		PLAIN	CHROME INSERT	CHROME & GUSSET	PENETRATOR (IH) CHROME
*Pictures are for Illustration Only. Actual Part May Not Look <i>Exactly</i> the Same.					
TO FIT		RP21507 Shown	RCKRAUSE Shown	RCHDMI-150H Shown	RCHJ21507IH Shown
CASE / IH 1" SHANKS		RP-10	N/A	N/A	RCHC14X PLEASE SPECIFY SHANK THICKNESS
CASE / IH #14 RIPPER 1-1/4" SHANKS		N/A	N/A	N/A	RCHC14X PLEASE SPECIFY SHANK THICKNESS
DMI 1-1/4" SHANKS (DMI Tiger)		N/A	N/A	RCHDMI-125H	N/A
DMI 1-1/2" SHANKS (DMI Tiger)		N/A	N/A	RCHDMI-150H	N/A
KRAUSE 1-1/4" SHANKS		N/A	RCKRAUSE	N/A	N/A
POINTS BELOW FIT MULTIPLE MACHINES - DO NOT USE PHOTO REFERENCES AT THE TOP OF THE PAGE FOR THESE RIPPER POINTS					
DMI/KRAUSE/ GREAT PLAINS 1-1/4" SHANKS		RC5WDMI-125H 5" Half Fold Wings		RC7WDMI-125H 7" Half Fold Wings	
DMI/KRAUSE/ GREAT PLAINS 1-1/2" SHANKS		RC5WDMI-150H 5" Half Fold Wings		RC7WDMI-150H 7" Half Fold Wings	

PENETRATOR (IH) CHROME & GUSSET	WINGS & GUSSET	SHARK FIN	SHARK FIN & WINGS
			
<i>RCHJ21507IHG Shown</i>	<i>RCWDMI-125H Shown</i>	<i>RCSC14X Shown</i>	<i>RCSW14X Shown</i>
N/A	N/A	N/A	N/A
RCHC14G	N/A	RCSC14X	RCSW14X
N/A	RCWDMI-125H	N/A	N/A
N/A	RCWDMI-150H	N/A	N/A
N/A	N/A	N/A	N/A

POINTS BELOW FIT MULTIPLE MACHINES • DO NOT USE PHOTO REFERENCES AT THE TOP OF THE PAGE FOR THESE RIPPER POINTS

RC10WDMI-125H 10" Half Fold Wings	RCS7WDMI-125H 7" Half Fold Wings & Shark Fin Chrome	
RC10WDMI-150H 10" Half Fold Wings	 <p><u>NEW CHROME & WING DESIGN FOR ALL DMI POINTS</u></p>	<p><i>For DMI, Great Plains & Krause</i></p>



NORWEST

MANUFACTURING

71 SOUTH 215 WEST-RUPERT, ID- PHONE: (208) 436-1770 - FAX: (208) 436-1776

SECTION 600 - C

RIPPER POINTS



JOHN DEERE

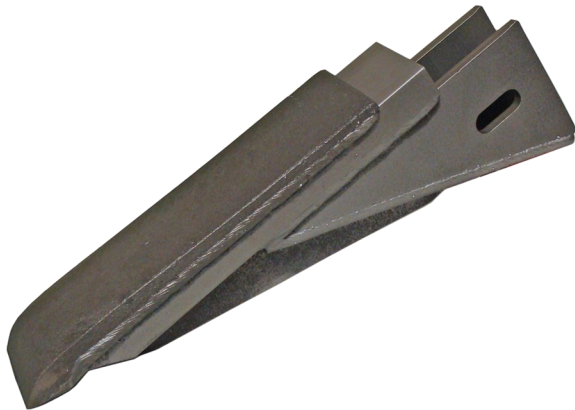

MISKIN

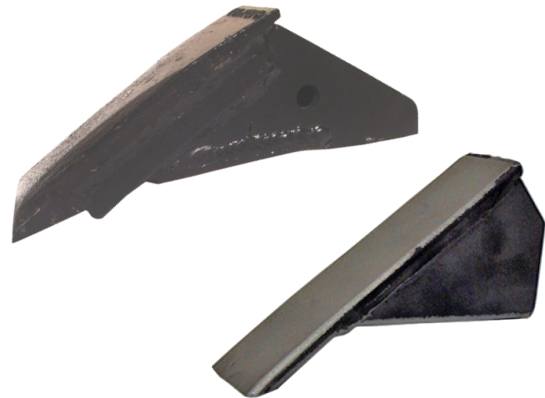

OPTIMIZER / PENGGO

SUB-SOILER POINT OPTIONS



***Pictures are for Illustration Only. Actual Part May Not Look *Exactly* the Same.**

NORWEST MANUFACTURING		PLAIN	CHROME INSERT	CHROME & GUSSET	PENETRATOR (IH) CHROME	PENETRATOR (IH) CHROME & GUSSET
TO FIT		RP21507 Shown	RCHJ21507 Shown	RCHJ21507G Shown	RCHJ21507IH Shown	RCHJ21507IHG Shown
JOHN DEERE <i>NO POCKET</i>		RPJ17994	RCHJ17994	N/A	N/A	N/A
JOHN DEERE <i>1-1/4" SHANKS</i>		RPJ21507	RCHJ21507	RCHJ21507G	RCHJ21507IH	RCHJ21507IHG
MISKIN		RHM67 Hard Faced	RCHM67	N/A	N/A	N/A
OPTI-MIZER <i>1" SHANKS</i>		N/A	RCHO-3420	N/A	N/A	N/A
PENGO <i>3/4" SCARIFIER SHANKS</i>		175	N/A	N/A	N/A	N/A

WINGS	WINGS & GUSSET	SHARK FIN	SHARK FIN & GUSSET	SHARK FIN & WINGS	SHARK FIN, WINGS & GUSSET
					
<i>RCHWJ21507 Shown</i>	<i>RCHWJ21507G Shown</i>	<i>RCSJ21507 Shown</i>	<i>RCSJ21507G Shown</i>	<i>RCSWJ21507 Shown</i>	<i>RCSWJ21507G Shown</i>
N/A	N/A	N/A	N/A	N/A	N/A
RCHWJ21507	RCHWJ21507G	RCSJ21507	RCSJ21507G	RCSWJ21507	RCSWJ21507G
N/A	N/A	N/A	N/A	N/A	N/A
N/A	N/A	N/A	N/A	N/A	N/A
N/A	N/A	N/A	N/A	N/A	N/A



NORWEST

MANUFACTURING

71 SOUTH 215 WEST-RUPERT, ID- PHONE: (208) 436-1770 - FAX: (208) 436-1776

SECTION 600 - D

RIPPER POINTS & SHANKS



SUNFLOWER



TYE



WATTS



WILCOX



WILRICH

SUB-SOILER POINT OPTIONS

PLAIN

CHROME
SERT

IN-

CHROME &
GUSSET

***Pictures are for Illustration Only.
Actual Part May Not Look *Exactly*
the Same.**



TO FIT

RP21507 Shown

RCHJ21507 Shown

RCHW10067 Shown

SUNFLOWER
1-1/4" SHANKS



N/A

N/A

N/A

SUNFLOWER
1-1/2" SHANKS



N/A

N/A

N/A

TYE
1-1/2" SHANKS



N/A

N/A

N/A

WATTS
NO POCKET
*(Fits J.D., Watts &
Dammer Diker)*



RPW17994

RCHW17994

N/A

WATTS
1-1/4" SHANKS



N/A

RCHW1005

N/A

WILCOX

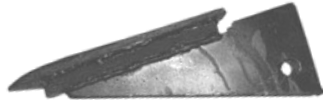

N/A

N/A

RCHW10067

WILRICH
1-1/2" SHANKS
(Old Style)



N/A

N/A

N/A





WILRICH
1-1/2" SHANKS
(New Style)



N/A

N/A

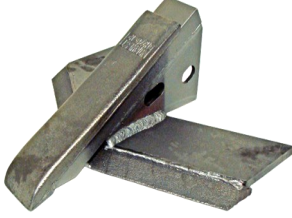
N/A

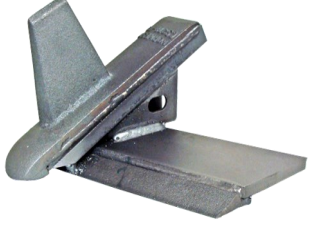
PENETRATOR (IH) CHROME	PENETRATOR (IH) CHROME & GUS- SET	WINGS	SHARK FIN	SHARK FIN & WINGS
				
<i>RCHT559 Shown</i>	<i>RCHT559G Shown</i>	<i>RCHWWR236551 Shown</i>	<i>RCSJ21507 Shown</i>	<i>RCSWJ21507 Shown</i>
N/A	N/A	RCHF1025	N/A	N/A
N/A	N/A	RCHF1025H	N/A	N/A
RCHT559	RCHT559G	N/A	N/A	N/A
N/A	N/A	N/A	N/A	N/A
RCHW1005IH	RCHW1005IHG	N/A	RCSW1005	RCSWW1005
N/A	N/A	N/A	N/A	N/A
N/A	N/A	RCHWWR1025	N/A	N/A
N/A	N/A	RCHWWR236551	N/A	N/A

Ripper Shanks



For **BIG OX** Rippers

Norwest Part #

RS-OX42

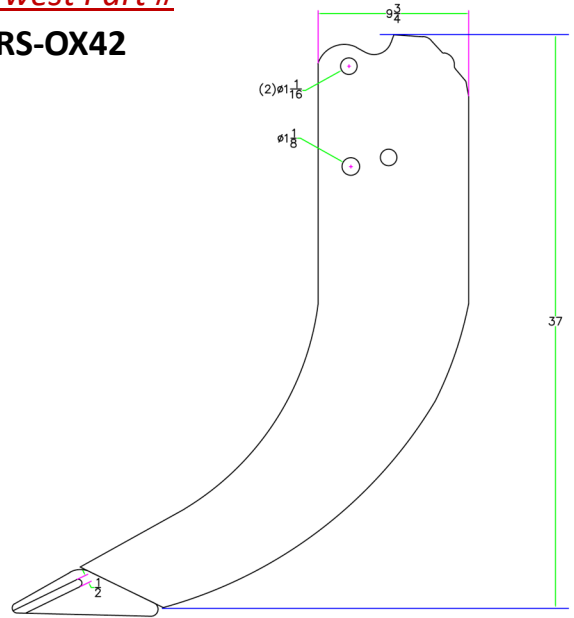

1" T1 Ripper Shank - Plain

Norwest Part #

RSC-OX42

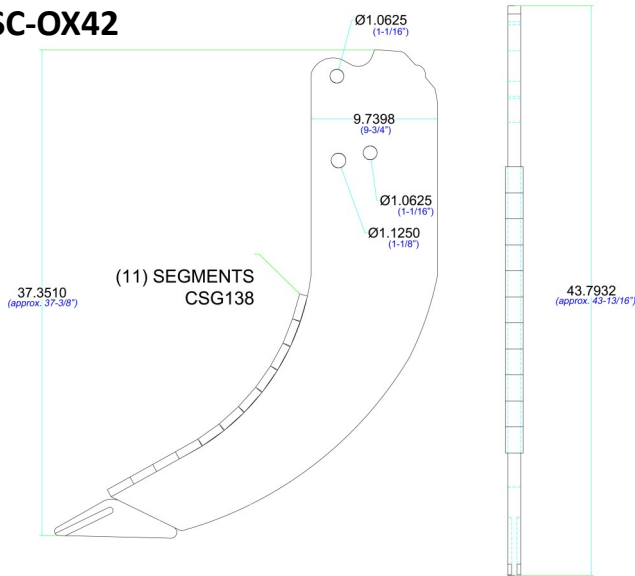

1" T1 Ripper Shank - with Chrome Shin Guard

Norwest Part #

RSCP-OX42

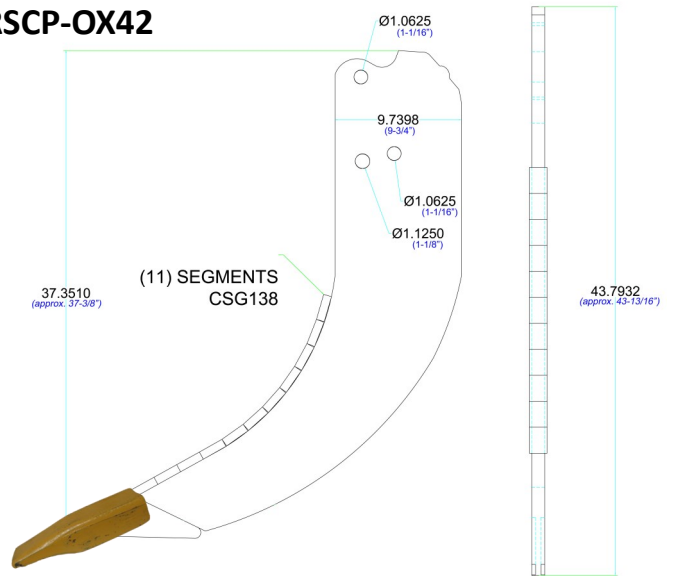

1" T1 Ripper Shank - with Chrome Shin Guard & RP2D-5 Plain Drop Forged Point

Ripper Shanks



Norwest Part #

RS131639C1

For old Style #14 Case Rippers

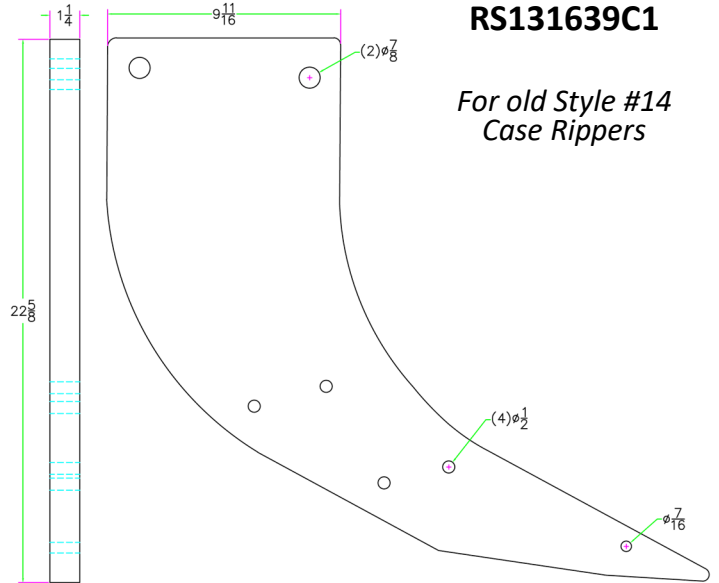

1-1/4" T1 Ripper Shank - Plain

Norwest Part #

RS92618

For **BRENT/CPC & UNVERFERTH** Rippers

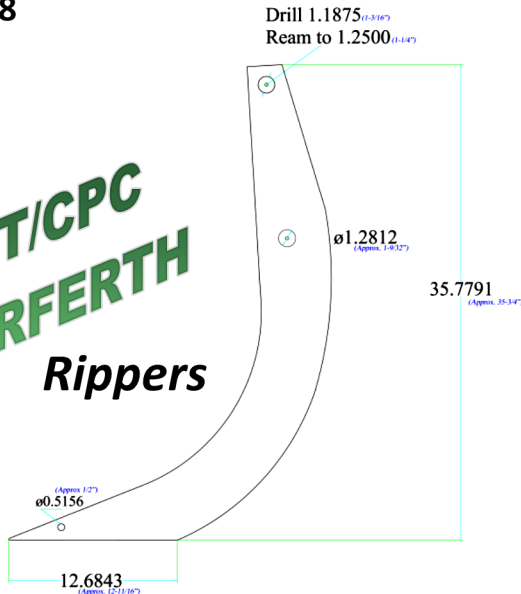

1-1/4" T1 Ripper Shank - Plain

Norwest Part #

RS9983476

Rear Replacement Shank

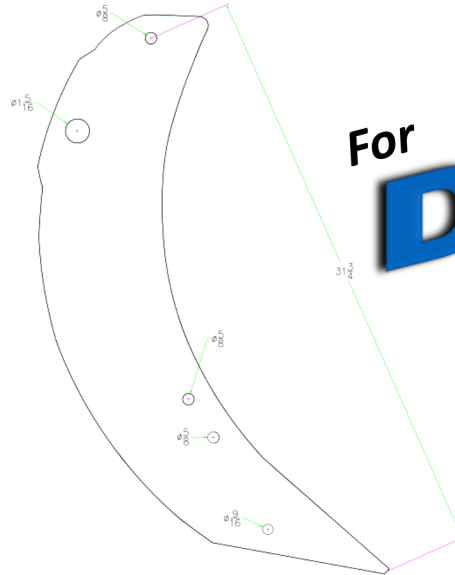

1-1/2" T1 Ripper Shank - Plain

For **DMI** Rippers

Ripper Shanks



For
JOHN DEERE
Rippers

Norwest Part #

RS-J2406
for 900V-Ripper

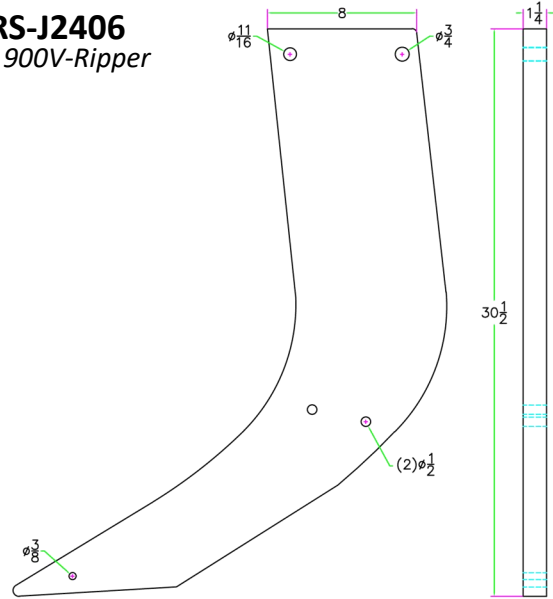

1-1/4" T1 Ripper Shank - Plain

Norwest Part #

RSC-J2406
for 900V-Ripper

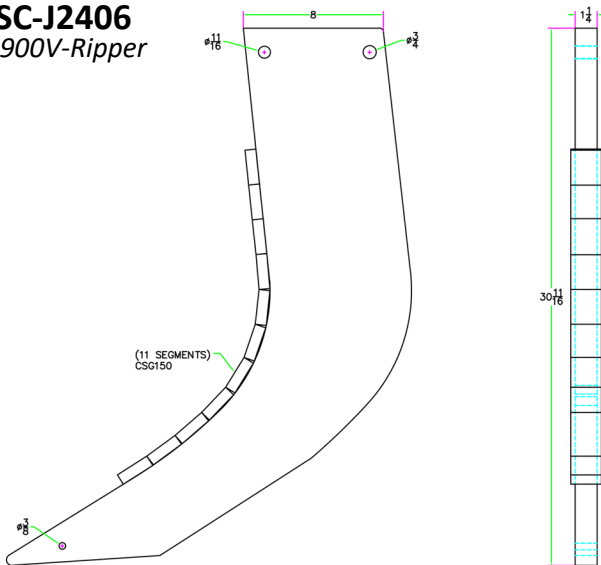

1-1/4" T1 Ripper Shank - with Chrome Shin Guard

Norwest Part #

RSCP-J2406
for 900V-Ripper

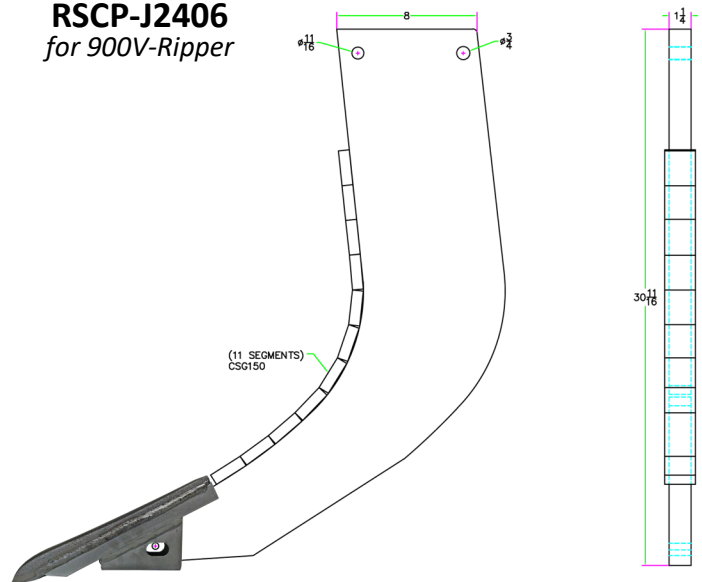

1-1/4" T1 Ripper Shank - with Chrome Shin Guard
& RCHJ21507 Chrome Point

Ripper Shanks

Norwest Part #
RS-M125

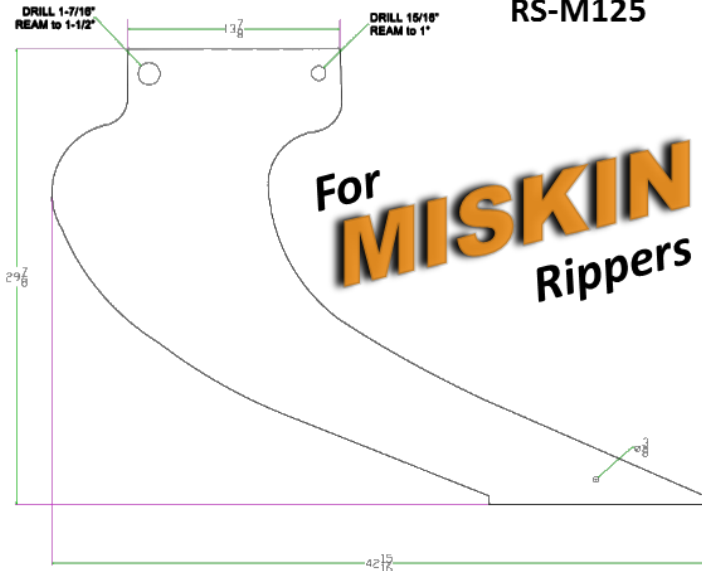

For MISKIN Rippers

1-1/4" T1 or Plow Steel Ripper Shank - Plain

Norwest Part #
RSC-M125

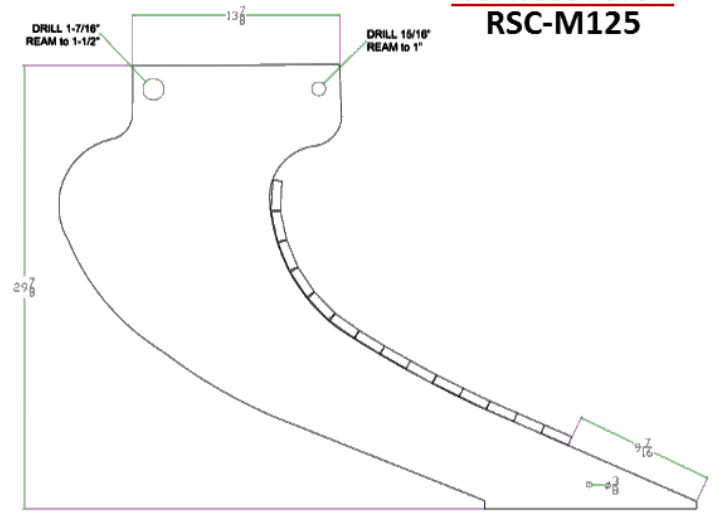

1-1/4" T1 or Plow Steel Ripper Shank - Chrome Shin Guard

Norwest Part #

OPTIMIZER

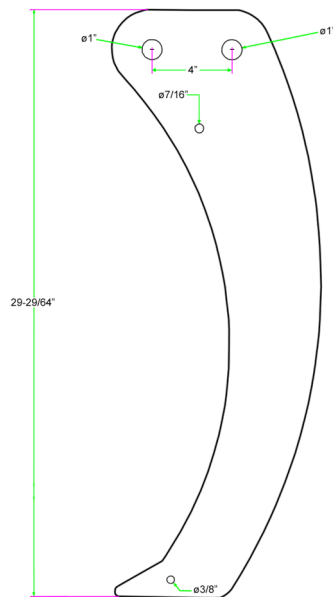

1" T1 Shank - Plain

Norwest Part #

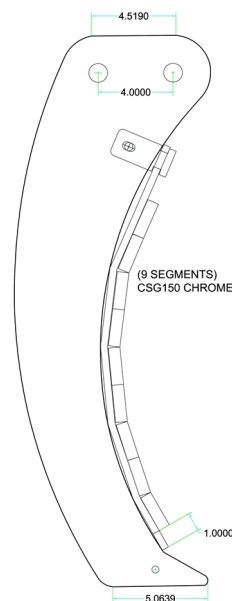

1" T1 Shank - w/Bolt-On Shin Guard

Norwest Part #

RSG-OPT4000
Bolt-On Shin Guard

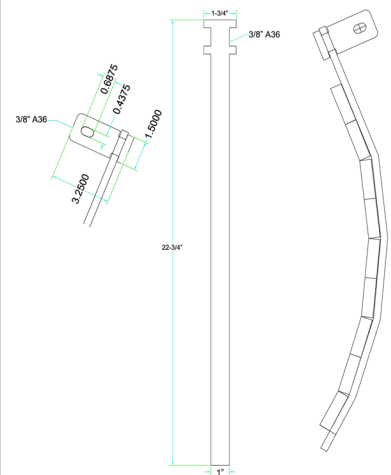

3/8" A36 Bolt-On Shin Guard w/ 7/16" x 11/16" Bolt Slot & 1-1/2" Chrome Segments

Ripper Shanks

For
WATTS
Rippers

Norwest Part #
Z-WATT1AA

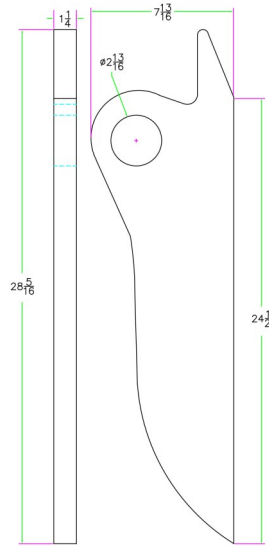

1-1/4" T1 - Replacement for Top Half of Watts Ripper Shank - Plain

Norwest Part #
7-WATT1AB

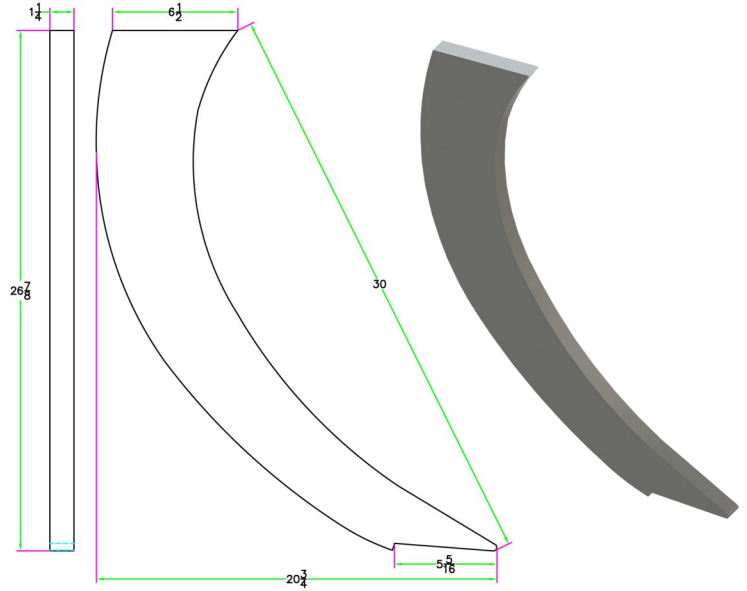

1-1/4" T1 - Replacement for Bottom Half of Watts Ripper Shank - Plain

Norwest Part #
Z-WATT1AC

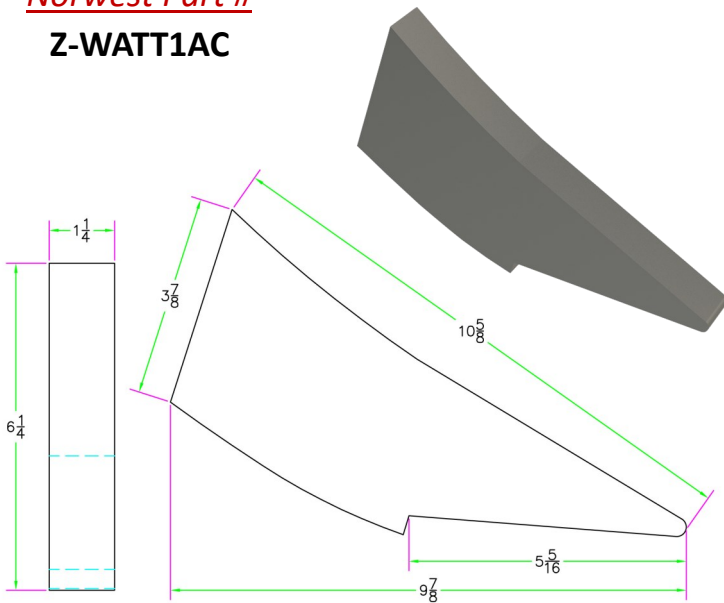

1-1/4" T1 - Replacement Tip for Watts Ripper Shank - Plain



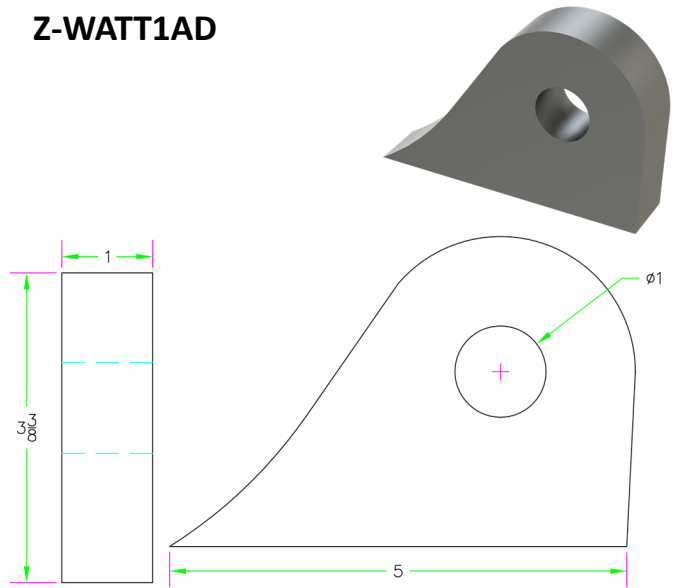

Norwest Part #
Z-WATT1AD

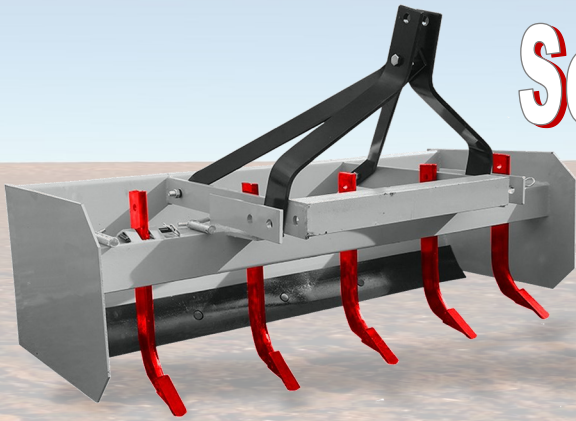

1" T1 - Replacement Ear for Watts Ripper Shank - Plain

Scarifier Points & Shanks for Box Scrapers



PART	NORWEST PART NUMBER	DESCRIPTION	LENGTH	MATERIAL THICKNESS	WIDTH	HOLE SPACING	HEAT TREATED
	M-10145B	3 HOLE	16"	3/4"	2-1/2"	1.5" CENTERS	POINT ONLY
	M-10145F	4 HOLE	18"	3/4"	2-1/2"	2.0" CENTERS	SHANK & POINT
	M-10145S	3 SLOT FRONT	18"	3/4"	2-1/2"	3.6" CENTERS	SHANK & POINT
	M-10145S2	2 SLOT FRONT	16"	3/4"	2-1/2"	2.5" CENTERS	SHANK & POINT
PART	NORWEST PART NUMBER	STYLE	MATERIAL		TO FIT		
	175	CRIMP ON - STANDARD <i>(NOT FLARED)</i>	HEAT TREATED STEEL HARDNESS: RC 38-42		M-10145B, M-10145F & M-10145S ▪ Other 3/4" Shanks		

! Norwest carries shanks and points only. We do not stock the box scraper units or curved scraper blades.





NORWEST

MANUFACTURING

71 SOUTH 215 WEST-RUPERT, ID- PHONE: (208) 436-1770 - FAX: (208) 436-1776

REPLACEABLE PARTS

Fits 1-1/4" and 1-1/2" Shanks

PART	NORWETS PART #	DESCRIPTION	FOR USE WITH
	RMDMICP1	REPLACEMENT SOLID CHROME TIP	Can be used on <u>ALL</u> Norwest Multi- Piece Ripper Points
	RMDMICP2	REPLACEMENT TWO PC. DUCTILE TIP FOR BOTH RMDMI-125D & 150D	Can be used on <u>ALL</u> Norwest Multi- Piece Ripper Points
	RMDMIPIN	REPLACEMENT ROLL PIN	Can be used on <u>ALL</u> Norwest Multi- Piece Ripper Points

CHROME OPTIONS FOR RIPPER POINTS

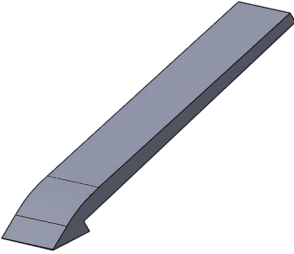
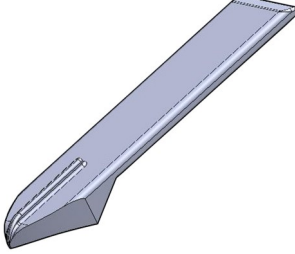
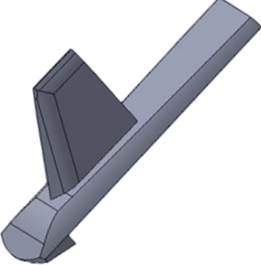
<i>New Style DMI Chrome</i>	<i>Blunt Nose Chrome</i>	<i>Penetrator Chrome</i>	<i>Shark Fin Chrome</i>
			
CH250-12 (DMI)	CH278-12 (JD)	CHT258-12 (IH)	CS278-12

WING & GUSSET OPTIONS

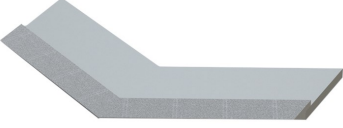
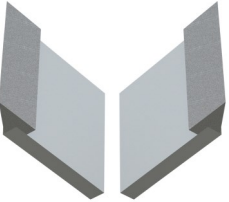
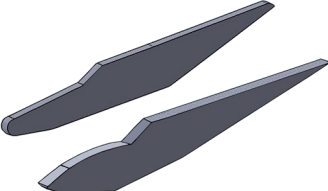
<i>Folded Wing</i>	<i>1 Piece Wing</i>	<i>2 Piece Wing</i>	<i>Gussets</i>
			
New DMI Wing	Delta Wing		

Looking for Chrome? See our Catalog: Section 700 - Chrome Inserts